

## YUASA FS Packing List

### Mechanical Endurance Testing System

#### Packing List for YUASA Jig FS

1. 1 x FS Jig and parts as shown in figure below.

2. 1 x Joint Bracket



3. 2 x Washer Assembled Cap Screws M4x10, (3 mm Allen Wrench), (the screws should be on the Jig in the mounting holes that connect the Jig to the Motor Unit Joint Bracket).



4. 1 x Floating Joint [ET136A001-004]



The Jig should be fully assembled in the shipping box. The Tilt Controllers and the Clamping Plates should be attached to the Jig. The Washer Assembled Cap Screws should be attached to the Jig. If you are shipping the Jig, these items may have been removed during use and they must be put back in place before shipping.

This drawing shows each of the pieces that are part of the Jig.

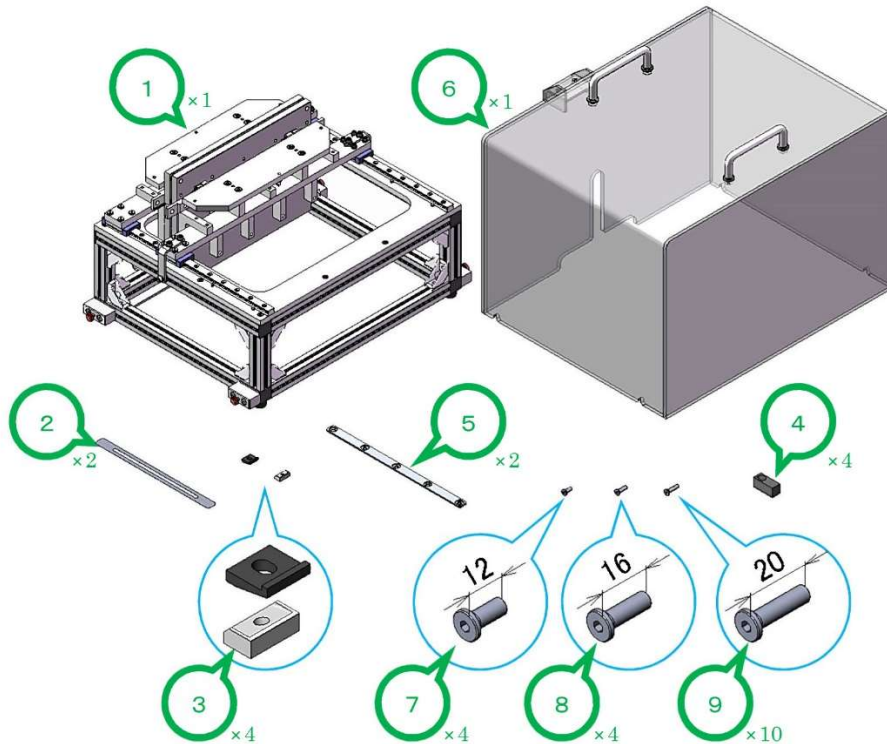

No	NAME	TYPE	MANUFACTURE (MATERIAL)	NOTE
1	Basic unit, tension-free folding	ET254A002-005	YUASA SYSTEM	
2	Tilt controller	ET200P165-006	YUASA SYSTEM	
3	Support, tilt controller	ET200P170-002+P170-006	YUASA SYSTEM	
4	Fixing block, tilt clamp	ET200P164-005	YUASA SYSTEM	
5	Clamping plate	ET200P005-045+P006-006	YUASA SYSTEM	
6	Safety Cover	ET500A003-025	YUASA SYSTEM	For Test Jig
7	Extra low head cap screw	CBSM5-12	MISUMI	To fix Tilt Clamp
8	Extra low head cap screw	CBSM5-16	MISUMI	To fix Tilt Controller
9	Extra low head cap screw	CBSM5-20	MISUMI	