

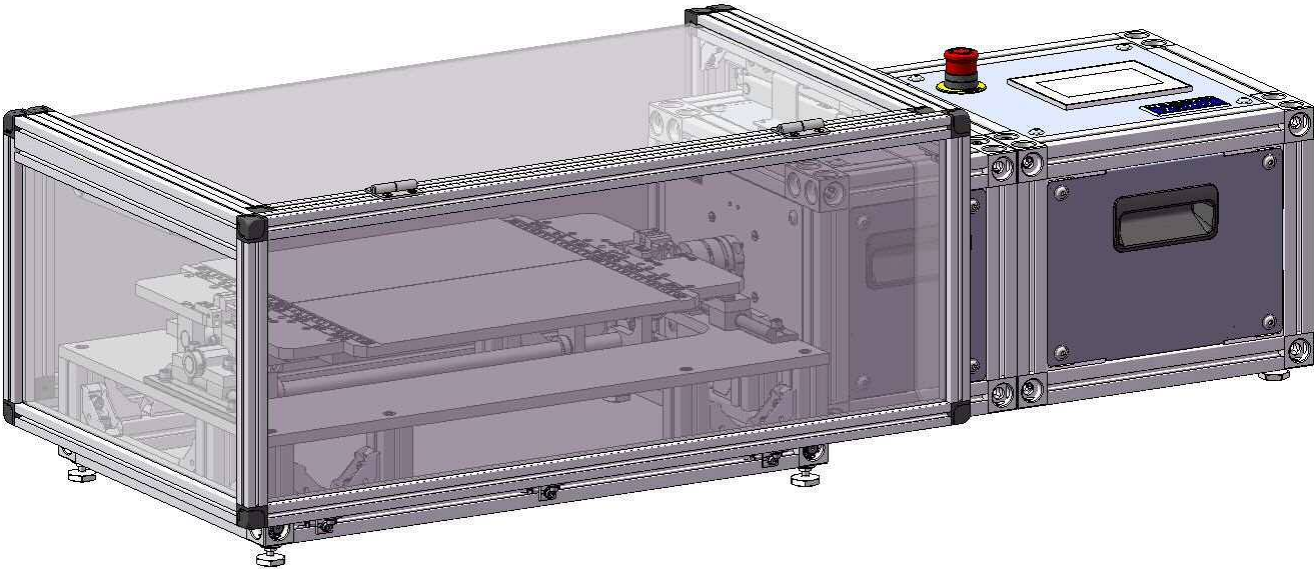

INSTRUCTION MANUAL  
TENSION-FREE FOLDING  
CLAMSHELL-TYPE

BF0101MR-DR11MR-M-1



### Safety precaution are classified into five categories

- WARNING** : Death or serious injury may result from not following product installation instruction.
- CAUTION** : Minor injury, as well as damage to the product may result from not following product instruction.
- NOTICE** : Inaccurate data may result from not following the test instructions.
- NOTE** : General knowledge.
- INTERLOCK** : Effect of the interlock system for safety.

- INTERLOCK** : Install the safety cover and prevent access to any moving parts.
- WARNING** : Installing, operating, maintaining or inspecting must be carried out by skilled and professional engineers.
- WARNING** : Make sure to tighten each screws as described in this manual.
- WARNING** : Make sure the Emergency Stop Button is maked work, and the machine is completely stopped before adjust the testing condition and change the part.
- WARNING** : Make sure the power is switched off, and the machine is completely stopped before carrying out maintenance and inspection.
- WARNING** : Do not use products beyond its capacity as specified in the specification.
- WARNING** : Do not remodel.
- CAUTION** : Do not change installation environment (temperature and humidity) rapidly.
- CAUTION** : Isolate the machine from sunlight.
- CAUTION** : Isolate the machine from any noise.
- CAUTION** : Isolate the machine from any dust.
- CAUTION** : Isolate the machine from large vibration.
- CAUTION** : Immediately stop the machine upon any sign of abnormal operation.
- NOTICE** : Make sure to tighten the screws as described in the manual.
- NOTE** : In some cases, illustrations with different shapes may be included.
- NOTE** : In some cases, a description different from your equipment may be included.
- NOTE** : The scraps should be disposed as general waste by skilled professionals.

# - CONTENTS -

1. INTRODUCTION	
1.1 OVERVIEW .....	1-1
1.2 STRUCTURE and COMPONENT .....	1-1
1.3 INSTALLATION .....	1-2
3. SETTING of TESTING CONDITON	
3.1 FOLDING SPEED .....	3-1
3.2 FOLDING RADIUS .....	3-1
3.3 SAMPLE .....	3-2
3.4 CARTRIDGE .....	3-2
3.4.1 PUT OUT THE CARTRIDGE .....	3-2
3.4.2 PUT ON THE CARTRIDGE .....	3-2
3.5 SAFETY COVER .....	3-3
3.5.1 ATTACH THE COVER to THE DRIVE UNIT .....	3-3
4. MAINTENANCE and INSPECTION	
4.1 INSPECTION .....	4-1
4.1.1 PARTS LIST .....	4-1

## [- NOTICE -]

We make absolutely sure about the contents of this user manual.  
However, if you have some questions or find some incorrect, please contact us.

# 1. INTRODUCTION

## 1.1 OVERVIEW

Sample's size	Thickness : Max. 1 mm
	Width : Max. 300 mm
	Length : Min. $\pi R$ +Clamping Space
Bending angle	180°
Bending radius	0.5 ~ 5.0 mm
Bending force	Max. 0.7 N·m
Rec. Speed	Max. 360 deg/sec (About 60 rec/min)
(Driving Unit)	(DR11MR)
Mass	Driving Unit : About 20.0 kg (44.1 lb)
	Test Jig : About 22.0 kg (48.5 lb)
	Cartridge: About 3.0 kg (6.6 lb)
	Cover : About 3.3 kg ( 7.3 lb)
Installation Environment	Temp. : +5~+40° C (41~104° F) Humi. : 15~98%RH (No Condensation)

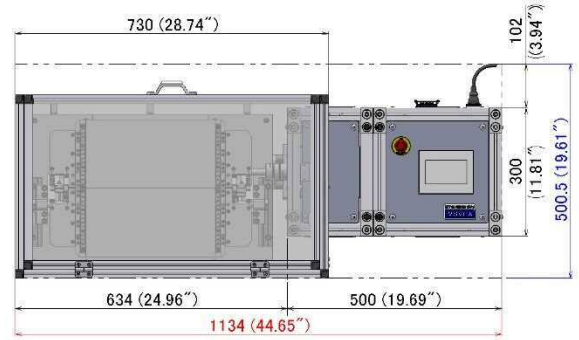

## 1.2 STRUCTURE and COMPONENTS

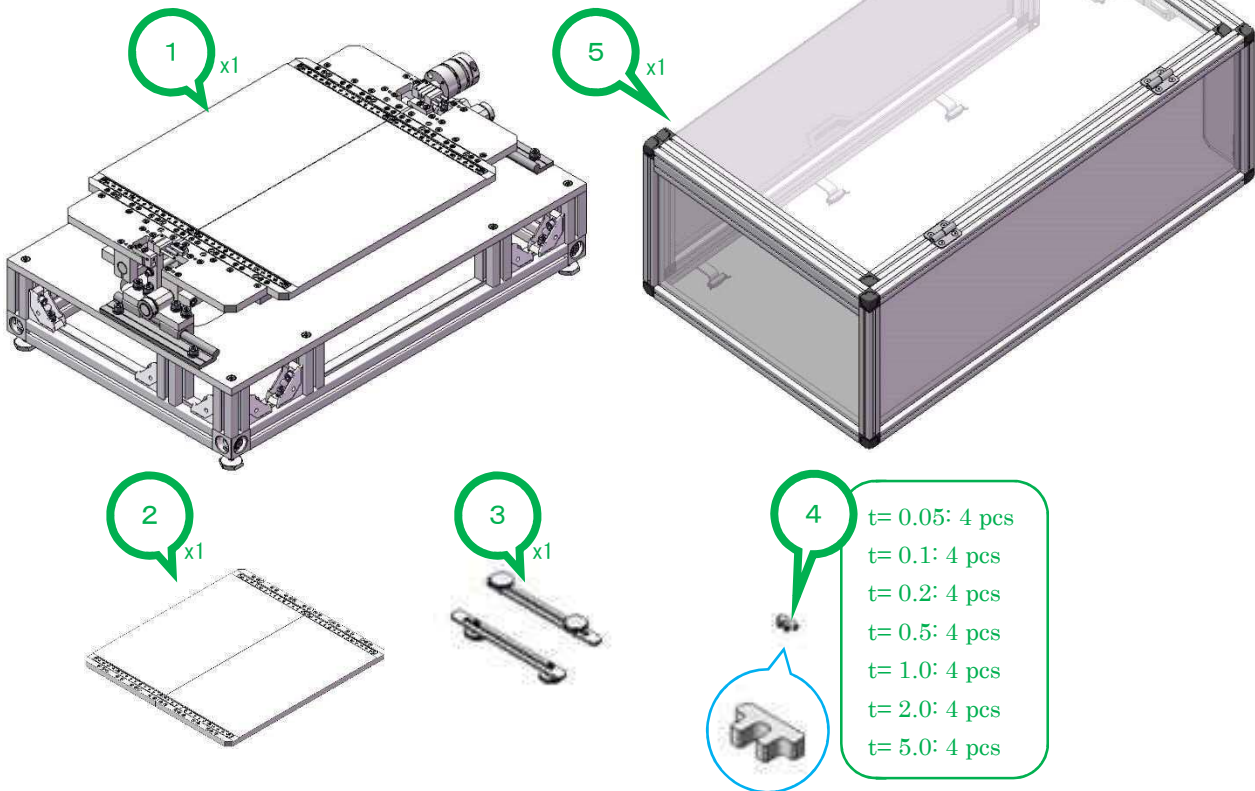

No	NAME	MANUFACTURE (MATERIAL)	NOTE
1	Basic unit	YUASA SYSTEM	
2	Holding plate	YUASA SYSTEM	For sample
3	Holding beam	YUASA SYSTEM	
4	Shim	YUASA SYSTEM	To set folding radius
5	Safety cover	YUASA SYSTEM	

**NOTE** The Cartridge consist of holding-plates and holding-beams.

### 1.3 INSTALLATION [ Tool: 3.0 mm Allen wrench ]

1) Confirm that the joint bracket (ET209009A0004) has been attached to the driving unit.

**NOTE** Cap screw M5x10 (4 pieces)

**CAUTION** Tightening torque: 6.7 N·m (do not over tighten screws)

2) Attach holding beams to keep holding plates horizontally.

3) Set target position of the driving unit to “-SP: 0” & “+SP: +90”.

**NOTE** Refer to the manual of the driving unit.

4) Locate the driving unit to zero degrees.

**NOTE** Refer to the manual of the driving unit.

5) Attach and push the testing jig to the driving unit.

**NOTE** Insert the driving shaft into the coupling.

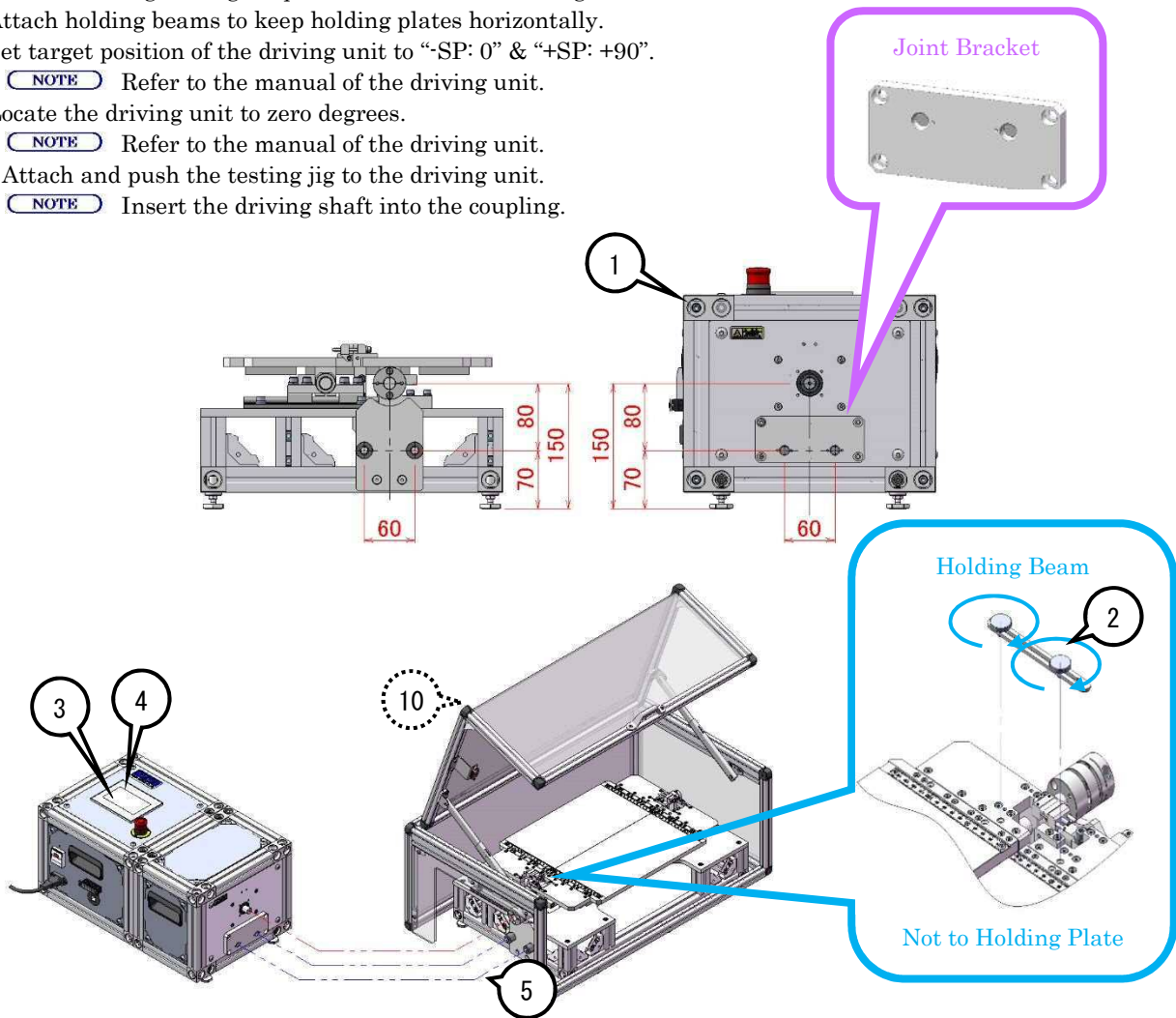

6) Tighten the screw to hold the driving shaft with the coupling.

**CAUTION** Tightening torque: 3.5 N·m (do not over tighten screws)

7) Remove holding beams from the testing jig.

8) Locate the driving unit to +90 degrees to confirm a pair of holding plates will be parallelly.

**NOTICE** If a pair of holding plates are not parallel, change the target position “+SP”.

9) Locate the driving unit to zero degrees again to confirm holding plates will be horizontally.

**NOTICE** If a pair of holding plates are not horizontal, change the target position “-SP”.

10) Close the safety cover and operate them slowly to confirm they move smoothly.

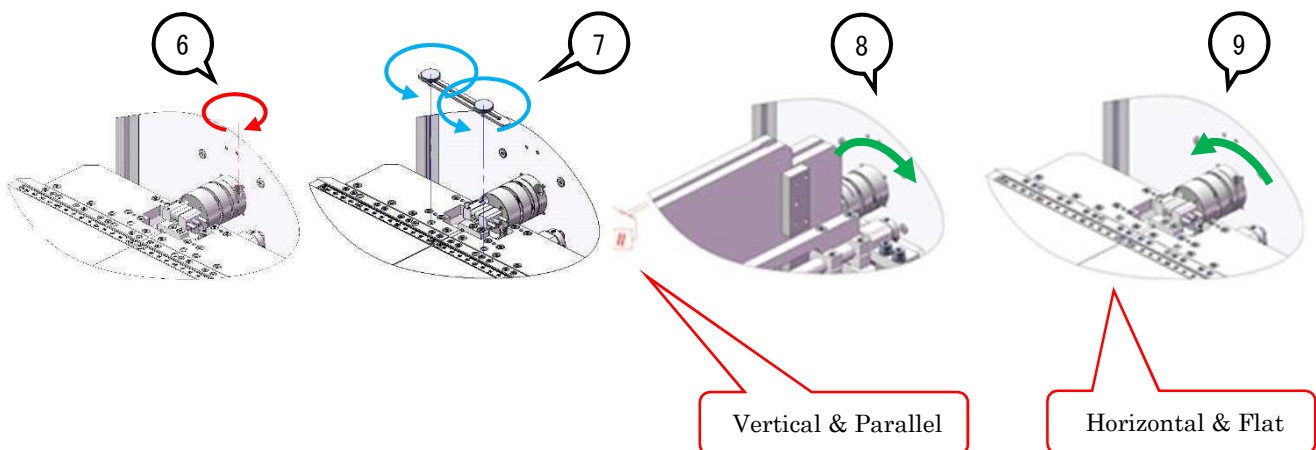

### 3. SETTING of TEST CONDITIONS

#### 3.1 FOLDING SPEED [ Tool: --- ]

**NOTE** Refer to the manual of the driving unit.

#### 3.2 FOLDING RADIUS [ Tool: 3 mm Allen wrench ]

1) Attach holding beams to hold the testing jig. Then loosen screws slightly so that the beam moves freely.

2) Loosen screws to remove shims. Then put some shims according to testing condition and hold them.

**NOTICE** Half of total thickness of shims mean folding radius. (Total thickness: 2R)

**NOTICE** Set surely same thickness shims into two places.

**CAUTION** Tightening torque: 3.0 N·m (do not over tighten screws)

**CAUTION** Do not set the folding radius less than 0.5 mm.

3) Remove holding beams.

4) Locate the driving unit to +90 degrees to confirm the distance between a pair of holding plates be shown 2R.

**NOTICE** If the distance between a pair of holding plates not become 2R, back to the process 2).

5) Locate back the driving unit to zero degrees.

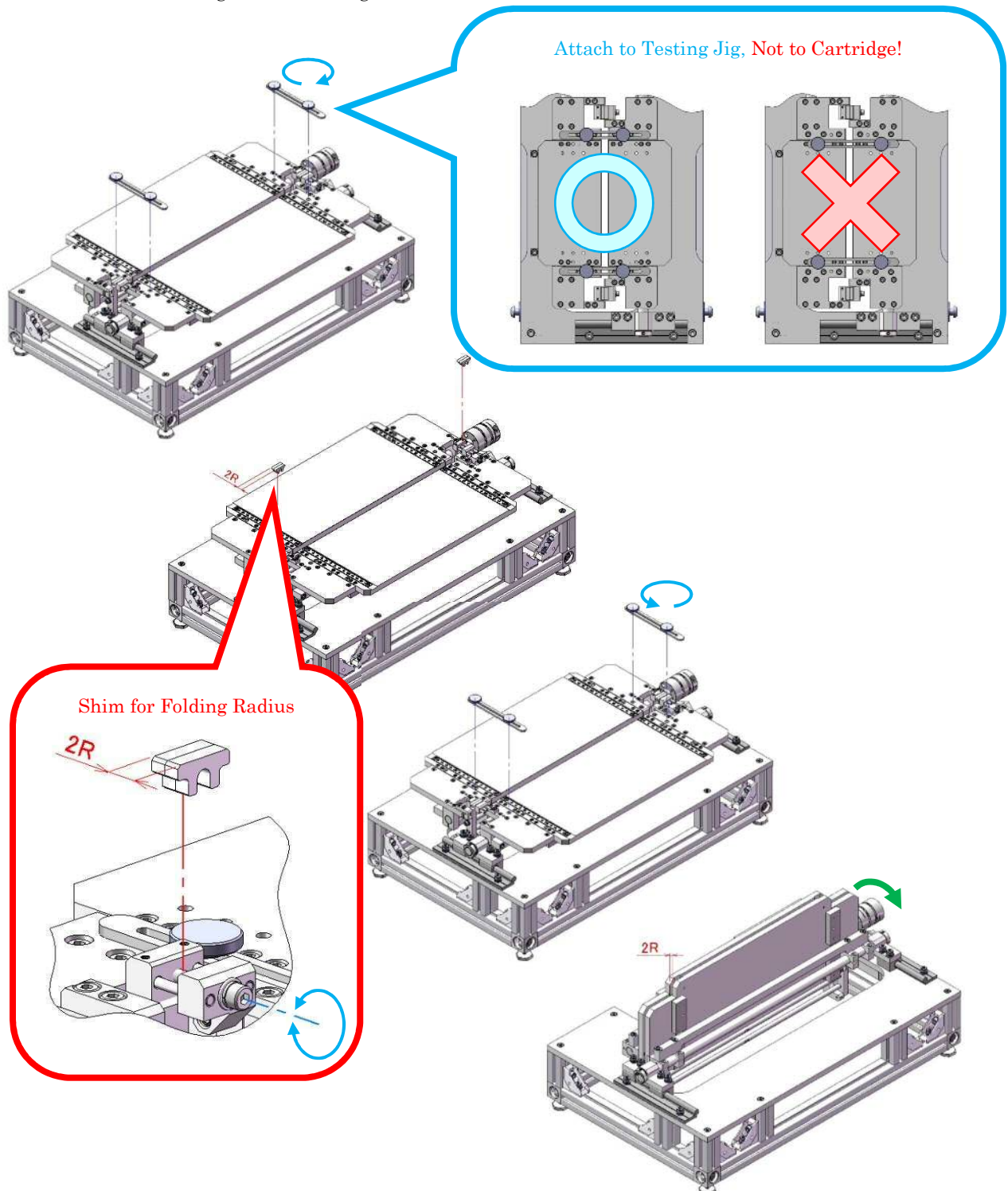

### 3.3 SAMPLE

- 1) Clean up holding plates.
- 2) Set the sample to holding plates with something adhesive tapes.

**CAUTION** Make sure that the sample never touch itself when it will be bent. The cartridge might detach and drop.

**NOTE** The huge force is not necessary to set the sample because the sample not will be subjected tension.

**NOTICE** The sample will be bent at center of a pair of holding plates.

**NOTICE** Adhesive should be made distance “ $(\pi R-2R)/2$ ” from the edge of the holding-plate.

Ex. Bending radius: 5 mm

$$(\pi R-2R)/2 = (3.14 \times 5 - 2 \times 5)/2 = \underline{2.85 \text{ mm}}$$

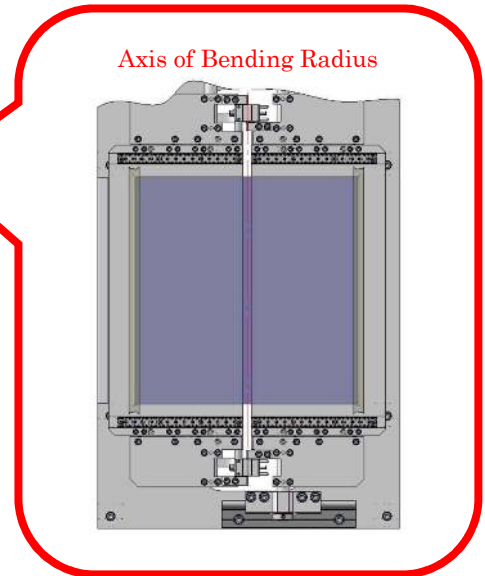
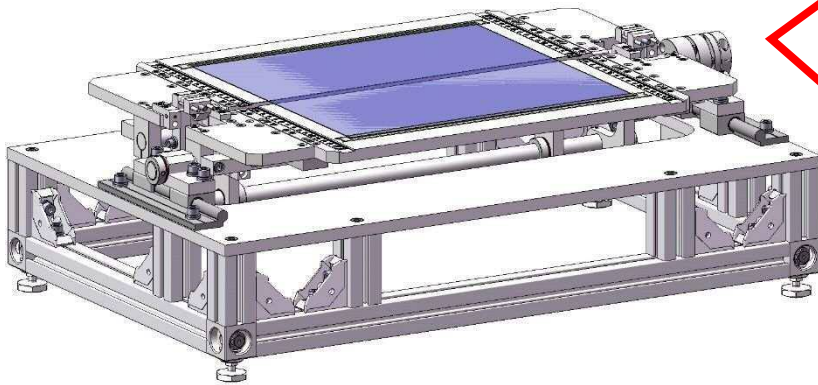

### 3.4 CARTRIDGE

Can remove samples together with the test jig, the cartridge, and reset it to continue test.

- Observe samples with the micro-scope repeatedly until tested number will reach to the target number.
- Change the material of the cartridge according to the sample.
- Change the shape of the cartridge according to the sample
- Etcetera.

#### 3.4.1 PUT OUT THE CARTRIDGE [ TOOL: - - - ]

- 1) Attach holding beams to holding plates.
- 2) Lift up the cartridge.

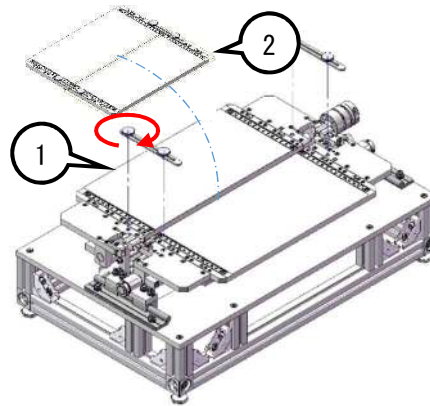

#### 3.4.2 PUT ON THE CARTRIDGE [ TOOL: - - - ]

- 1) Locate the cartridge with dowel pins, and put it on the testing jig.
- 2) Remove holding beams.

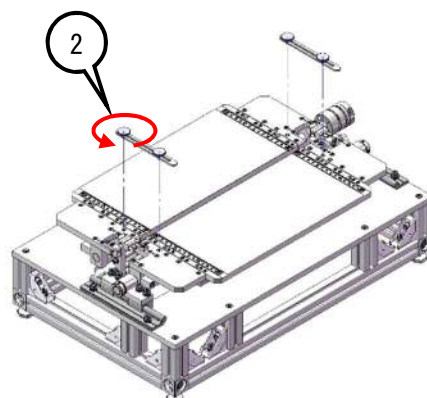
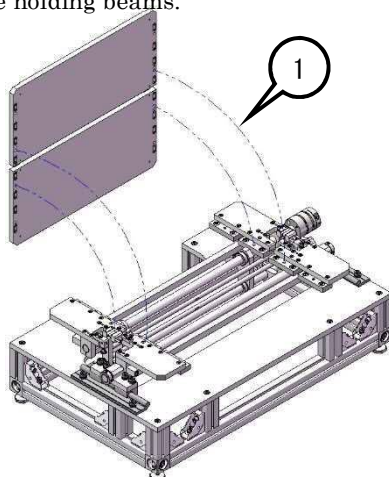

### 3.5 Safety Cover

**WARNING** Install a safety cover and prevent access to any moving parts.

**INTERLOCK** Cannot operate equipment with the operation panel whenever the safety cover opened.

#### 3.5.1 ATTACH THE COVER to THE DRIVE UNIT [Tool: --- ]

1) Attach the cover on the test jig to the drive unit.

**CAUTION** Confirm screws are fit in the ditch of the cover.

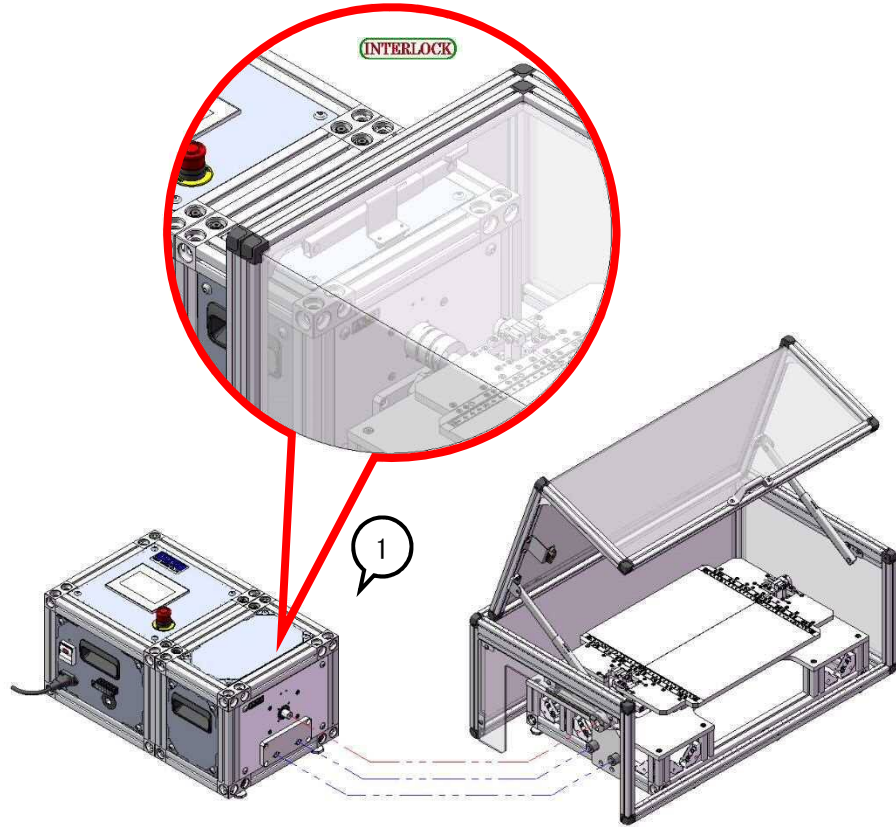



【MEMO】

## 4. MAINTENANCE and INSPECTION

### 4.1 INSPECTION

This Jig is maintenance-free.

Change to the new one if some components will break because of using condition or aging.

#### 4.1.1 PARTS LIST

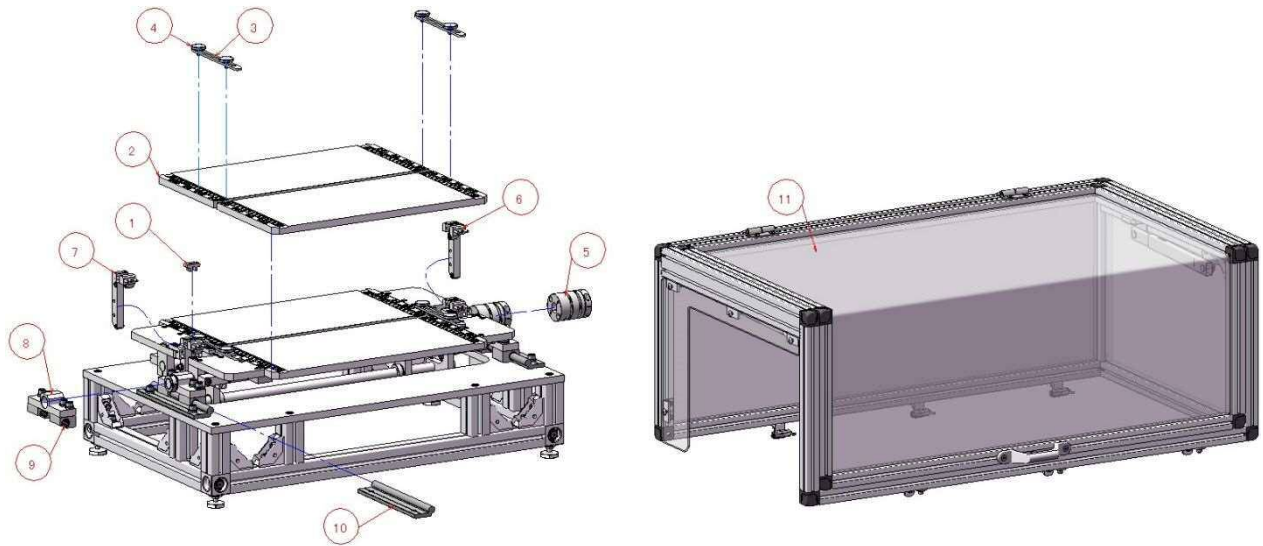

No	NAME	TYPE	Num.	MANUFACTURE (MATERIAL)	NOTE
1	Shim set	ET264008A001	1	YUASA SYSTEM	No.1-1~1-7 included
1-1	Shim	YS001P0000021	*1	YUASA SYSTEM	t= 0.05 mm
1-2	Shim	YS001P0000022	*1	YUASA SYSTEM	t= 0.1 mm
1-3	Shim	YS001P0000023	*1	YUASA SYSTEM	t= 0.2 mm
1-4	Shim	YS001P0000024	*1	YUASA SYSTEM	t= 0.5 mm
1-5	Shim	YS001P0000025	*1	YUASA SYSTEM	t= 1.0 mm
1-6	Shim	YS001P0000026	*1	YUASA SYSTEM	t= 2.0 mm
1-7	Shim	YS001P0000027	*1	YUASA SYSTEM	t= 5.0 mm
2	Cartridge	ET264003A0008-0 (*2)	2	YUASA SYSTEM	No.3 included
(3)	Holding beam	YP000P0000099	2	YUASA SYSTEM	No.4 included
(4)	Cover screw	RNCB5-3-8	4	MISUMI	
5	Disk coupling	GCPW39-15-15	1	MISUMI	
6	Parallel link	ET264005A0006	1	YUASA SYSTEM	
7	Parallel link	ET264005A0005	1	YUASA SYSTEM	
8	Slider	ET264007A0001	2	YUASA SYSTEM	No.10 included
9	Housing bearing	WJ200UM-01-10-AL	4	igus	
(10)	Single rail	WS-10-160	2	igus	
11	Safety cover	ET503004A0009	1	YUASA SYSTEM	

**NOTE** \*1: The number depends on testing condition.

**NOTE** \*2: Can order a cartridge with other material, please contact the sales agent.

**【MEMO】**

~ Further Improve Reliability



<http://www.yuasa-system.jp> ~

YUASA SYSTEM CO., LTD.

HEAD OFFICE / 2292-1, Kibitsu, Kita-ku, Okayama-shi,  
FACTORY: OKAYAMA 701-1341, JAPAN Tel. +81-86-287-9030 / Fax. +81-86-287-2298

TOKYO OFFICE: 3F, Shinbashi SN BLDG, 5-7-10, Shinmachi, Minato-ku,  
TOKYO 105-004, JAPAN Tel. +81-3-3578-8515 / Fax. +81-3-3578-8516

OSAKA OFFICE: 8F, NLC Shin-Osaka Earth-BLDG, 5-1-3, Miyahara, Yokogawa-ku, Osaka-shi,  
OSAKA 532-003, JAPAN Tel. +81-6-6394-8175 / Fax. +81-6-6397-2632

The Contents of the instruction manual may change to improve without notice.