

INSTRUCTION MANUAL

Endurance Testing Machine

DMLHP

ET000003M0003/00

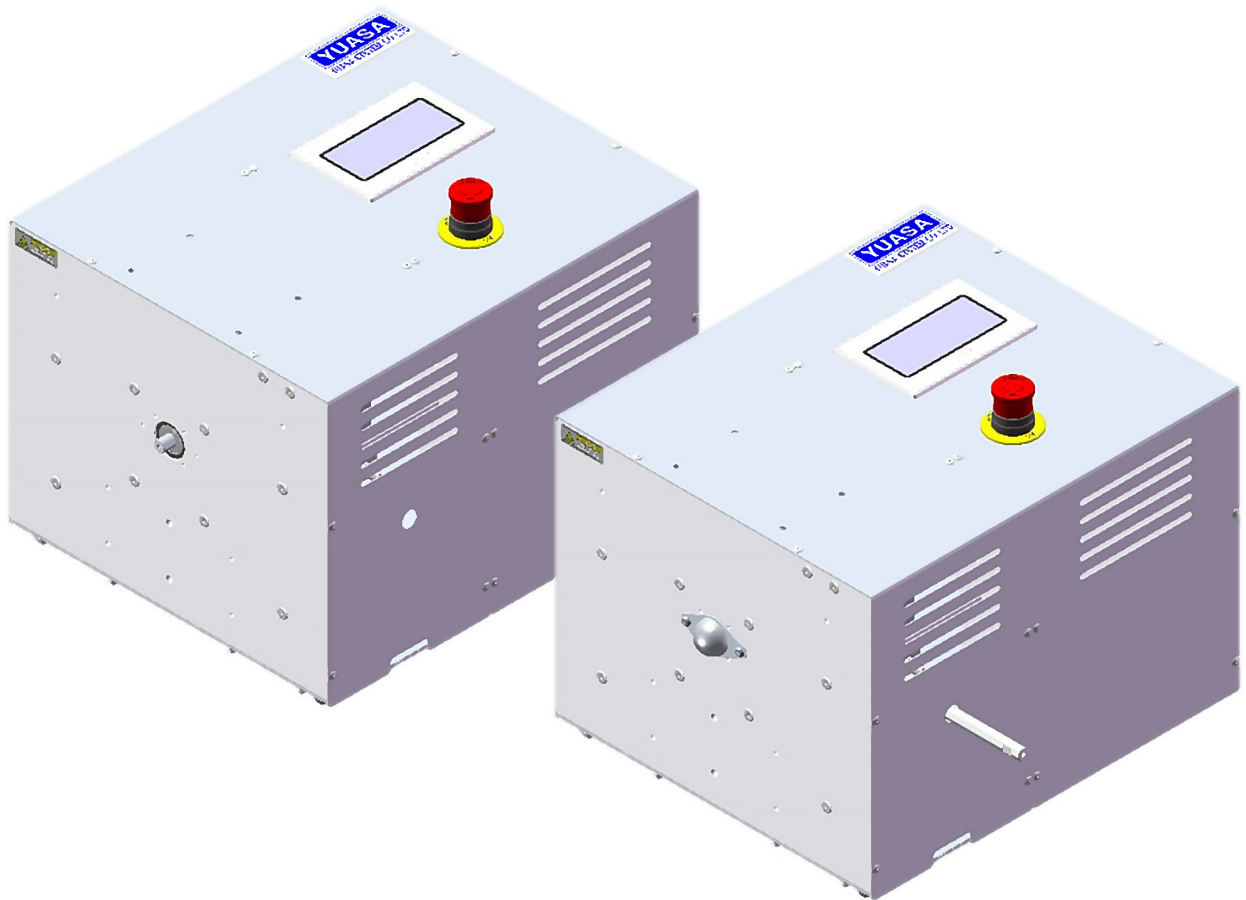

Safety precaution are classified into five categories

WARNING : Death or serious injury may result from not following product installation instruction.

CAUTION : Minor injury, as well as damage to the product may result from not following product instruction.

NOTICE : Inaccurate data may result from not following the test instructions.

NOTE : General knowledge.

INTERLOCK : Effect of the interlock system for safety.

INTERLOCK : Install a personal safety cover and prevent access to any moving parts.

WARNING : Installing, operating, maintaining or inspecting must be carried out by skilled and professional engineers.

WARNING : Make sure to tighten each screws as described in this manual.

WARNING : Make sure the Emergency Stop Button is maked work, and the machine is completely stopped before adjust the testing condition and change the part.

WARNING : Make sure the power is switched off, and the machine is completely stopped before carrying out maintenance and inspection.

WARNING : Do not use products beyond its capacity as specified in the specification.

WARNING : Do not remodel.

CAUTION : Do not change installation environment (temperature and humidity) rapidly.

CAUTION : Isolate the machine from sunlight.

CAUTION : Isolate the machine from any noise.

CAUTION : Isolate the machine from any dust.

CAUTION : Isolate the machine from large vibration.

CAUTION : Immediately stop the machine upon any sign of abnormal operation.

NOTICE : Make sure to tighten the screws as described in the manual.

NOTE : In some cases, illustrations with different shapes may be included.

NOTE : In some cases, a description different from your equipment may be included.

NOTE : The scraps should be disposed as general waste by skilled professionals.

Icons on this manual.

◇ Tap the touch panel display

◇ Press the touch panel display



- CONTENTS -

1. INTRODUCTION	
1.1 UTILITY INFORMATION	1-1
1.2 STRUCTURE and COMPONENTS	1-1
1.3 OUTLINE	1-2
1.4 INSTALLATION	1-2
1.4.1 DRIVING MODE SELECTION	1-2
1.5 SPECIFICATIONS	1-2
1.5.1 ROTARY RECIPROCATION MODE	1-3
1.5.2 LINEAR RECIPROCATION MODE	1-4
2. OPERATING INSTRUCTION	
2.1 BOOT UP	2-1
2.2 SHUT DOWN	2-1
2.3 OPERATION PANEL	2-1
2.4 PASSWORD	2-2
2.4.1 CHANGING PASSWORD	2-2
3. SETTING of TESTING CONDITON	
3.1 TESTING JIG	3-1
3.1.1 OUTPUT MODE SELECTION	3-1
3.1.2 SAFETY LIMIT for INPUT VALUE	3-2
3.1.3 COORDINATE	3-3
3.2 RECIPROCATING ANGLE or DISTANCE	3-3
3.3 RECIPROCATING SPEED	3-3
3.4 PRESET COUNTER	3-4
3.4.1 RESET COUNT	3-4
3.5 STOP SIGNAL	3-4
3.5.1 SELECT CONTACT (A or B)	3-4
3.6 OPERATION	3-5
3.6.1 START	3-5
3.6.2 STOP	3-5
3.6.2.1 STOP POSITION	3-5
3.6.3 JOG	3-5
3.6.4 POSITIONING	3-5
4. MAINTENANCE and INSPECTION	
4.1 INSPECTION	4-1
4.1.1 PARTS LIST	4-2
4.2 ERROR MESSAGE and CORRECTIVE ACTION	4-3
4.3 TROUBLESHOOTING	4-3
4.3.1 I/O CHECK	4-3
5. REMOTE CONTROL	
5.1 OUTLINE	5-1
5.2 FORMAT	5-1
5.2.1 BASIC FORM	5-1
5.2.2 REQUEST MESSAGES	5-1
5.2.3 RESPONSE MESSAGES	5-2
5.3 IP ADDRESS	5-2

[- NOTICE -]

We make absolutely sure about the contents of this user manual.
However, if you have some questions or find some incorrect, please contact us.

1. GENERAL DESCRIPTION

1.1 UTILITY INFORMATION

POWER	100~240 V / 50 or 60 Hz / 1 Phase / 100 VA
MASS	About 15 kg (About 33.07 lb)
INSTALLATION ENVIRONMENT	Temperature : +5~+40 ° C (41~104 ° F) Humidity : 15~85 %RH (No Condensation)
SOUND LEVEL	Max. 80 dB

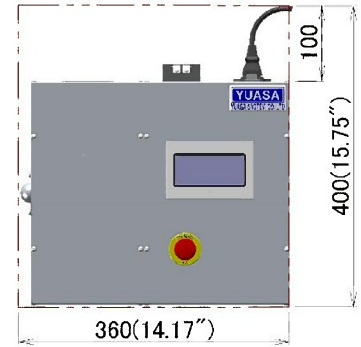

1.2 STRUCTURE and COMPONENTS

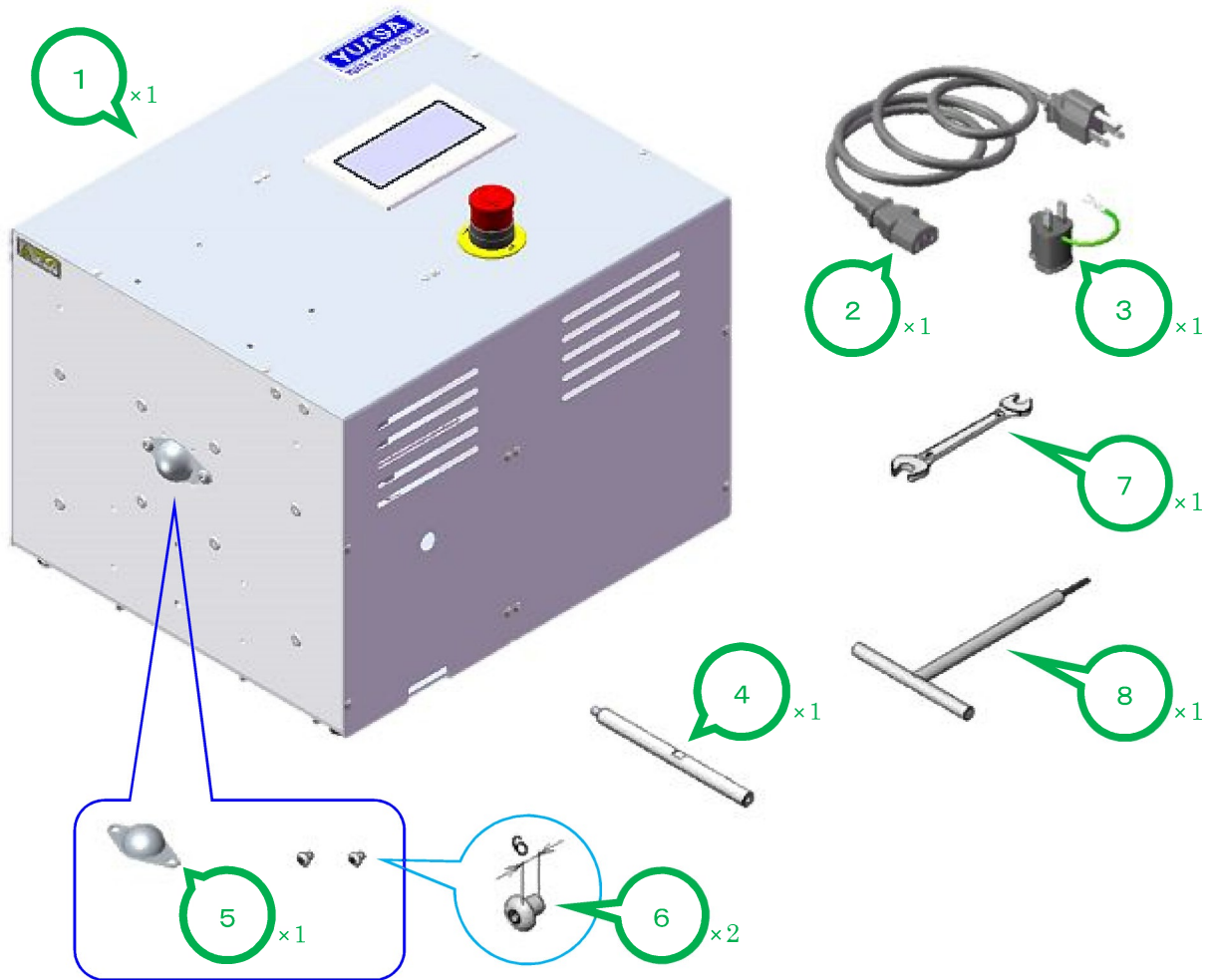

Nº	NAME	NUM.	NOTE
1	DMLHP	1	Main body
2	Power strip	1	2 m
3	Adapter	1	“3P” to “2P + Ground cable”
4	Linear shaft	1	For linear reciprocation mode
5	Shaft cover	1	For linear reciprocation mode
6	Button head screw	2	M5x6
7	Spanner	1	8 x 10 mm
8	T-type allen wrench	1	3 mm

1.3 OUTLINE

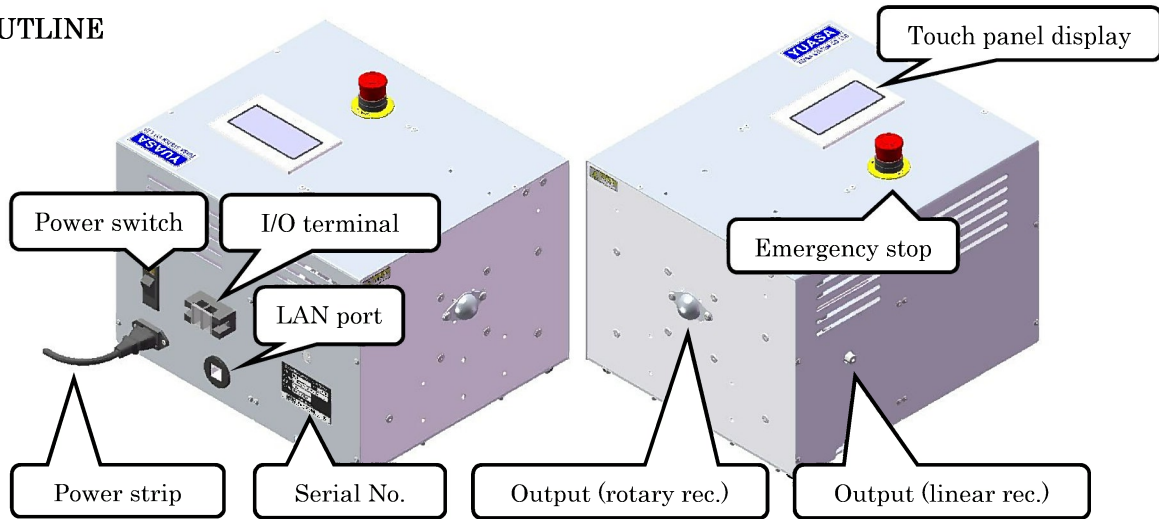

1.4 INSTALLATION

Prepare the setting space according to the specifications of testing jigs

- WARNING** Use only an included power strip.
- WARNING** Make sure to wire so as not to damage the power strip.
- WARNING** Ground a ground cable for safety.
- CAUTION** Install them on the strong rack, they might rock the rack.
- CAUTION** Do not hold the terminals or the power strip when move the DMLHP.
- CAUTION** Make sure not to squash finger between the DMLHB and the rack or the wall.

1.4.1 DRIVING MODE SELECTION

Can select the output mode from “rotary reciprocation mode” or “linear reciprocation mode”. Refer to “3.1.1 DRIVING MODE SELECTION” for more detail.

【Rotary reciprocation mode】

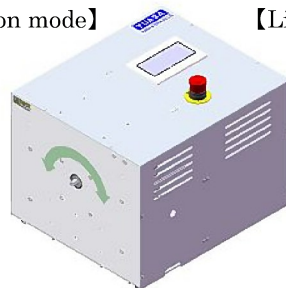

【Linear reciprocation mode】

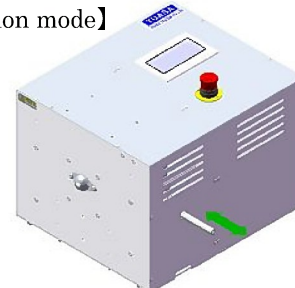

1.5 SPECIFICATIONS

- NOTICE** DMLHP stop about 0.2 seconds at each moving end position because DMLHP change a rotary direction of a stepping motor to output reciprocation.
- NOTICE** DMLHP may moves with two-stage acceleration as below.
- NOTE** Sp: Reciprocating speed [rec/min]

Moving with Constant Acceleration

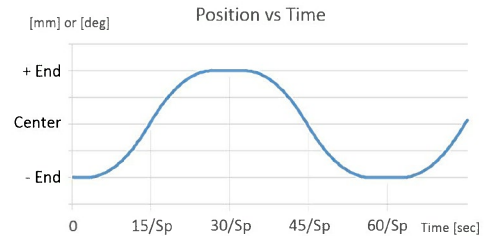

Moving with Two-Stage Acceleration (in case of short stroke and low reciprocating speed)

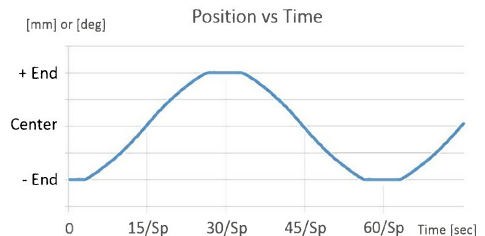
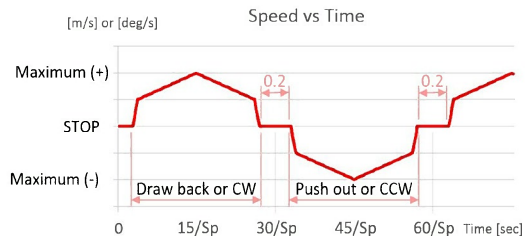

1.5.1 ROTARY RECIPROCATION MODE

DMLHB supplies rotary reciprocating motion for the bending test or twisting test or something.

CAUTION Function may be limited by kind of test jig or sample.

NOTE Output shaft: Diameter is 10 mm and length is 11 mm.

COUNTER	8-digits display (Can set the target number)
RECIPROCATING SPEED	As shown in the graph.
RECIPROCATING ANGLE	7.0~±270.0 [deg.] (in 0.1 deg. increments)
POSITIONING ACCURACY	0.25 [deg.] (by backlash)
PERMISSIBLE TORQUE	1.8 [N·m]
STATIC RATED MOMENT	1.5 [N·m]
PERMISSIBLE MOMENT of INERTIA	2.0×10^{-3} [kg·m ²]

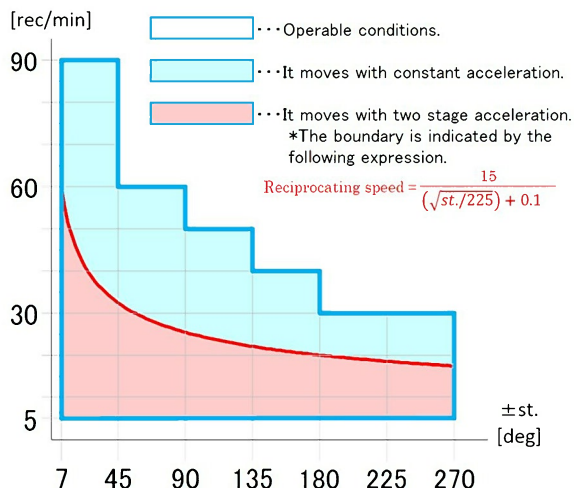

- Permissible Torque : It mean maximum power that the testing jig will transform samples.
- Static Rated Moment : It mean maximum mass (add up test jigs and samples) that attachable to output shaft.
⇒ Calculate it from each masses and each center of gravity positions.

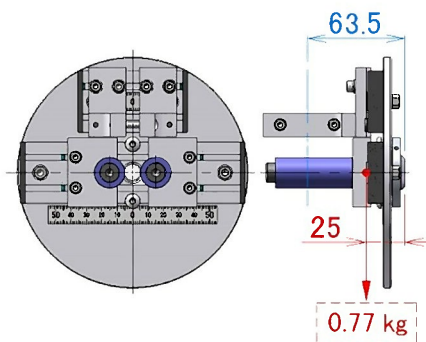
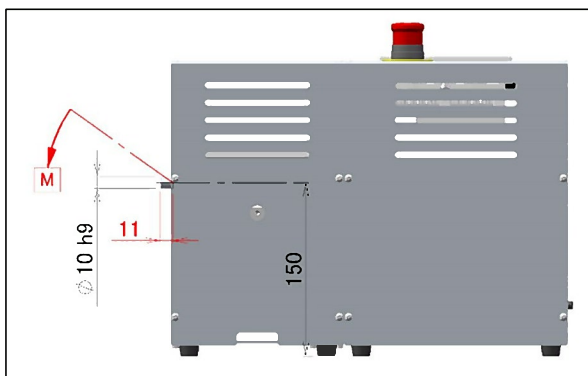

Ex. Bending Jig + Bending Radius Jig (R10)

- ◇ Test jigs
 - Center of gravity position : 25 mm
 - Mass : 0.77 kg
- ◇ Samples
 - Clamped position : 63.5 mm
 - Mass : 1.0 kg

$$\begin{aligned} \text{Static Rated Moment} &= 0.77 \times 9.81 \times 0.025 + 1.0 \times 9.81 \times 0.0635 \\ &= 0.81 \text{ [N·m]} < 1.5 \text{ [N·m]} \end{aligned}$$

- Permissible Moment of Inertia: It is index for checking relations of reciprocating speed and angle.
⇒ Refer to an attached sheet (instruction manuals and specifications of each testing jigs) for detail.

1.5.2 LINEAR RECIPROCATION MODE

DMLHB supplies linear reciprocating motion for the sliding-folding test or passing test or something.

CAUTION Function may be limited by kind of test jig or sample.

NOTE Output shaft: Diameter is 10 mm and internal thread M5 depth 10 to attach testing jigs.

COUNTER	8-digits display (Can set the target number)
RECIPROCATING SPEED	As shown in the graph.
RECIPROCATING DISTANCE	3.0~120.0 [mm] (in 0.1 mm increments)
POSITIONING ACCURACY	0.15 [mm] (by backlash)
OUTOPUT	72 [N]
STATIC RATED MOMENT	1.3 [N·m]

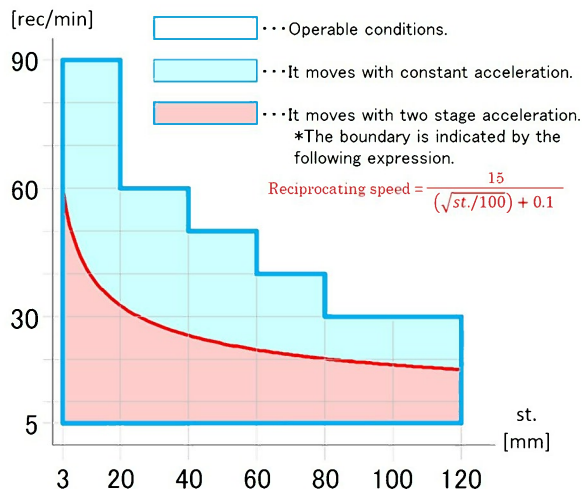

- Output : It mean maximum power (pushing power is same as pulling force).
- Static Rated Moment : It mean maximum mass (add up test jigs and samples) that attachable to output shaft.
⇒ Calculate it from each masses and center of gravity positions.

NOTE Do not include each masses of components supported by linear motion guide.

Ex. Floating joint

- Center of gravity position : 32 mm
- Mass : 0.056 kg

Static Rated Moment = 0.056 × (0.150 + 0.032)
 = 0.01 [N·m] < 1.3 [N·m]

2. OPERATING INSTRUCTION

2.1 BOOT UP

- 1) Connect a power strip (inlet) to outlet.
WARNING Ground a ground cable for safety.
- 2) Turn on the power switch.
- 3) The “HOME” screen boot up, over.
NOTE The endurance testing machine boots up automatically when electricity supplied.

2.2 SHUT DOWN

- 1) Make sure that every equipments stop.
- 2) Turn off the power switch.
NOTE There is no unique procedure of shut down.

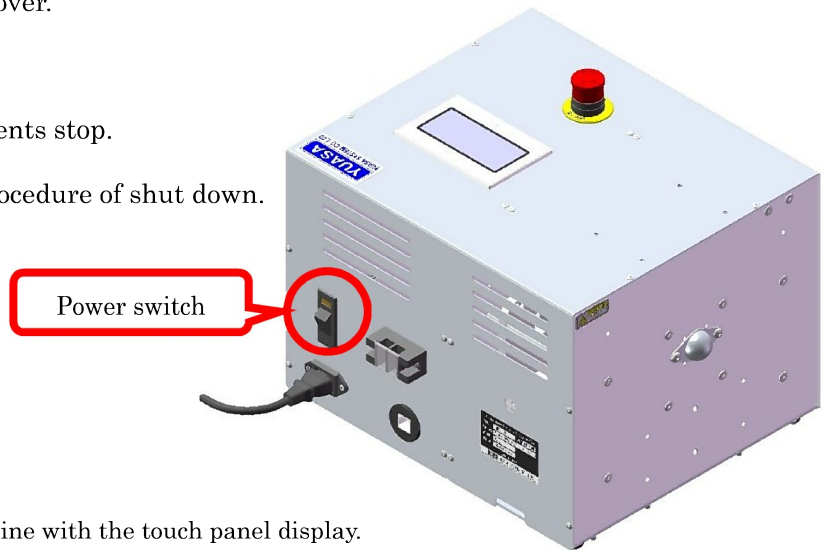

2.3 OPERATION PANEL

Operate the endurance testing machine with the touch panel display.

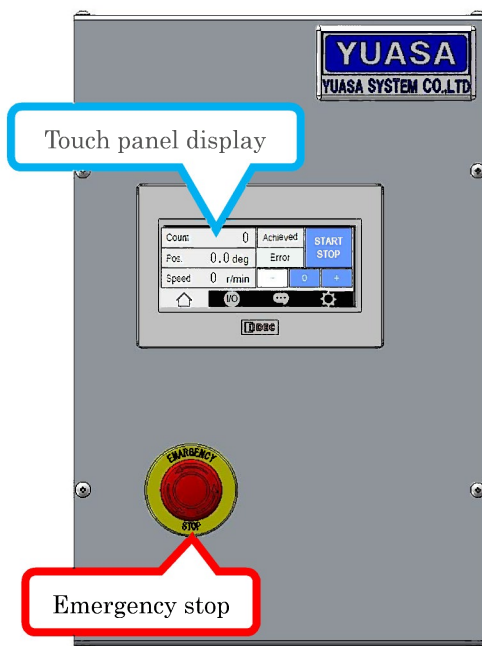

Tap each menu button to change the screen.
Refer to each instruction for detail, below.

- HOME screen:
3. SETTING and TESTING CONDITON
- I/O screen:
4. MAINTENANCE and INSPECTION
- MESSAGE screen:
4. MAINTENANCE and INSPECTION
- SETTING screen:
3. SETTING and TESTING CONDITION
5. REMOTE CONTROL

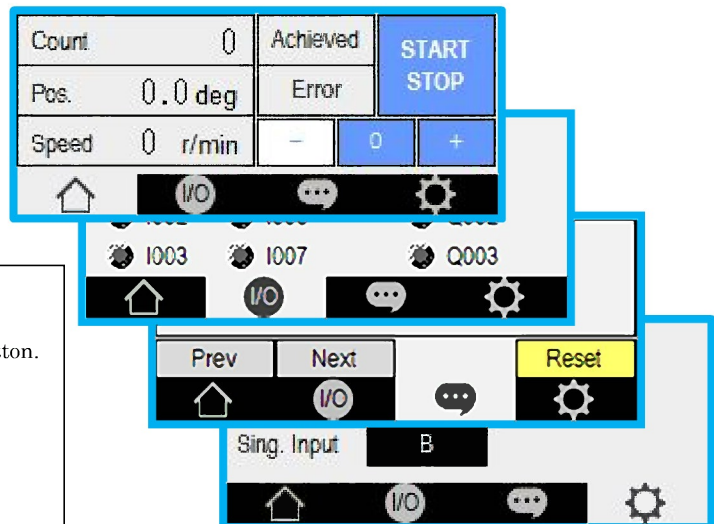

Tap the numeric display for each setpoint.
The keypad will be shown on the screen.
Enter the setpoint value and tap the “ENT” button.

1234567890			
7	8	9	CLR
4	5	6	CAN
1	2	3	ENT
0	+/-	.	

- NOTE Tap the “Language” button, the “language selection” window will pop up.
Can select language from English, Japanese, Korean or Chinese.
- NOTE Units will automatically change according to the output mode.
Refer to “3.1.1 OUTPUT MODE SELECTION” for detail.

2.4 PASSWORD

Must input password to change some parameter, below.

The default password is "0000", but should change it to personal one.

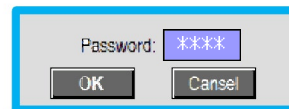

- NOTE** To select the output mode. Refer to "3.1.1 OUTPUT MODE SELECTION".
- NOTE** To input the safety limit value. Refer to "SAFETY LIMIT for INPUT VALUE".
- NOTE** To change the password. Refer to below.

2.4.1 CHANGING PASSWORD

- 1) Tap the "SETTING" icon twice to display the "SETTING" screen.
- 2) Tap the "PASSWORD" button, then input the current password.
- 3) Tap again the "PASSWORD" button to input a new password.
- 4) Make sure a displayed password, then tap the "Renew" button to complete changing.

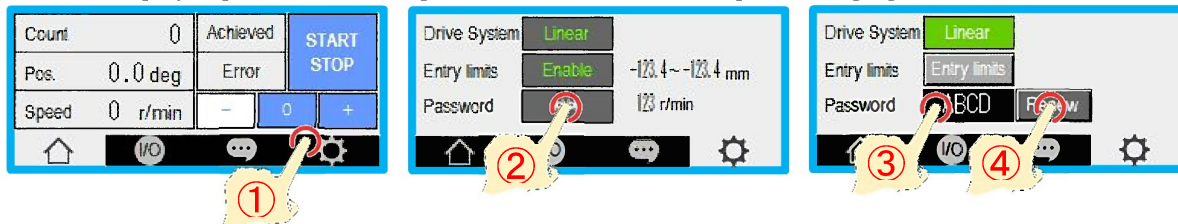

3. SETTING and TEST CONDITION

Can set various test mode and conditions.

It count a cycle every 1 reciprocation.

3.1 TESTING JIG

Choose and attach the testing jig to the rotary reciprocating shaft or the linear reciprocating shaft as necessary. Refer to attached sheets (instruction manuals and specifications) of each testing jigs, for detail.

3.1.1 OUTPUT MODE SELECTION [Tool: 3 mm T-type allen wrench, 8 mm spanner]

Can select the output mode from “rotary reciprocation mode” or “linear reciprocation mode”.

【Rotary reciprocation mode】

【Linear reciprocation mode】

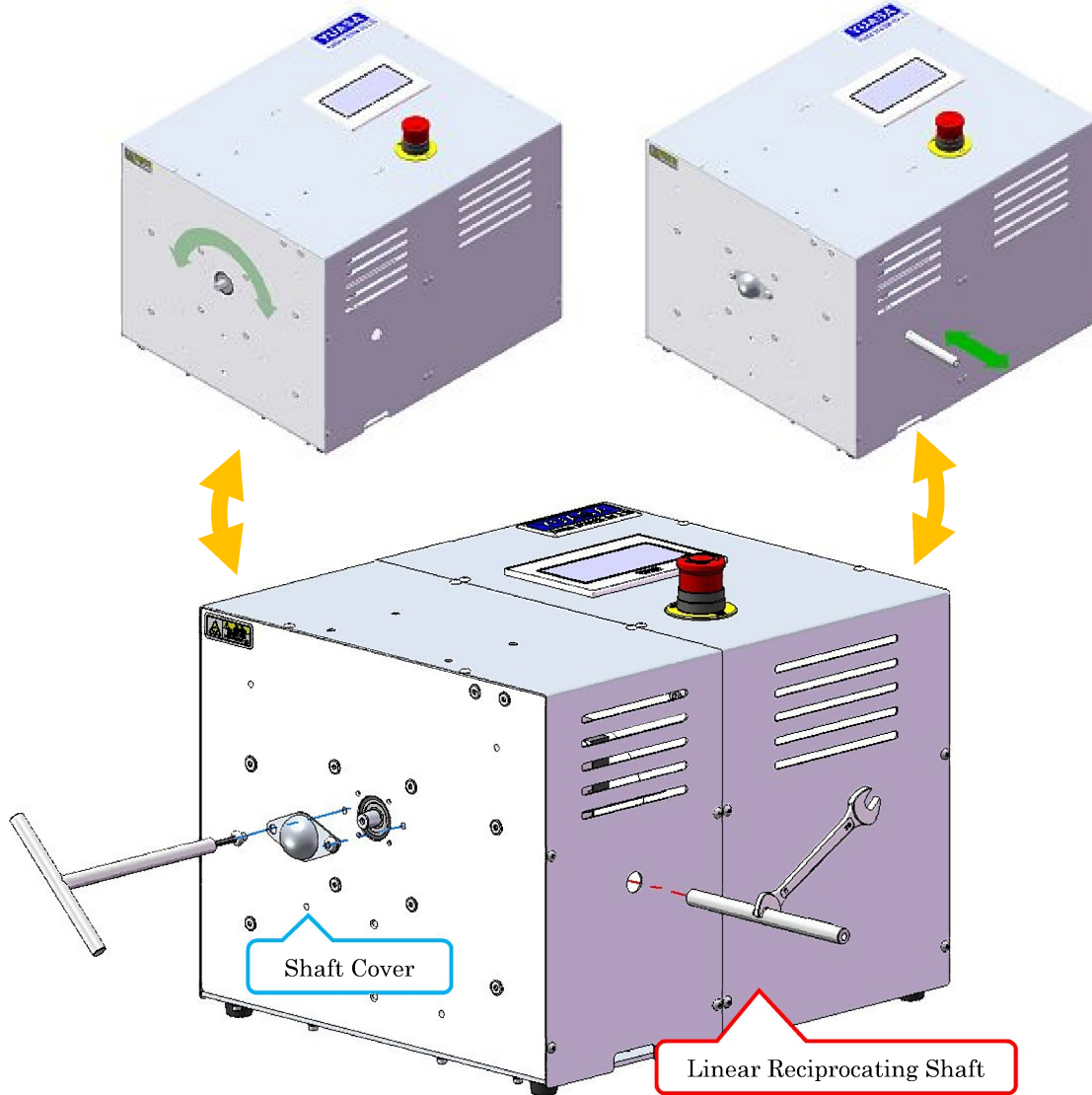

1) Attach the shaft-cover over the rotary reciprocating shaft or detach it.

CAUTION Make sure to attach the shaft-cover when using DMLHB in linear reciprocation mode.

CAUTION Tightening torque: 3.0 N·m (do not over tighten screws)

NOTE Use an included tool, T-type allen wrench.

2) Attach the linear reciprocation shaft or detach it.

CAUTION Make sure to detach the linear reciprocating shaft when use DMLHB in rotary reciprocation mode.

CAUTION Make sure to support the linear reciprocating shaft surely with hand when use spanner.

CAUTION Tightening torque: 6.5 N·m (do not over tighten screws)

NOTE Use an included tool, spanner.

3) Select the output mode (Drive system) at “SETTING” screen to change displayed units.

CAUTION Make sure that DMLHP is stopped before setting.

NOTE Have to input the password to change parameter.

3.1) Tap the "SETTING" icon twice to display the “SETTING” screen.

3.2) Tap the “OUTOPUT MODE” button, then input the password.

3.3) Tap and select the output mode (drive system).

Linear: Linear reciprocation mode

Rotary: Rotary reciprocation mode

3.4) Reboot DMLHP to complete setting.

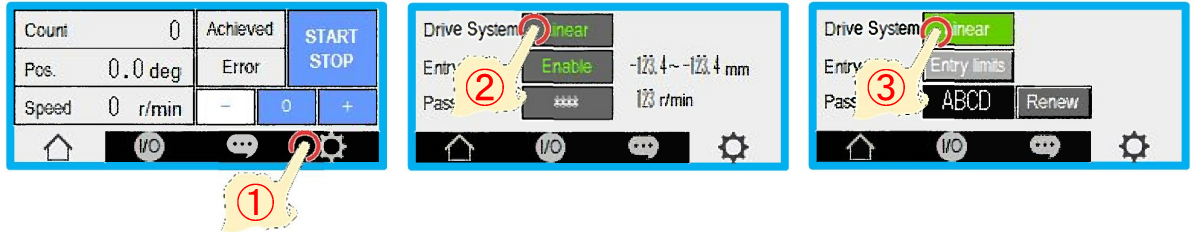

3.1.2 SAFETY LIMIT for INPUT VALUE

INTERLOCK Can set limit value to prevent from setting a wrong condition.

CAUTION Make sure that DMLHP is stopped before setting.

NOTE Have to input the password to change parameter.

(1) Tap the "SETTING" icon twice to display the “SETTING” screen.

(2) Tap the “Entry limit” button, then input the password.

(3) Tap again the “Entry limit” button to set each limit.

(4) Set each limit according to the testing jig.

(5) Reboot DMLHP to complete setting.

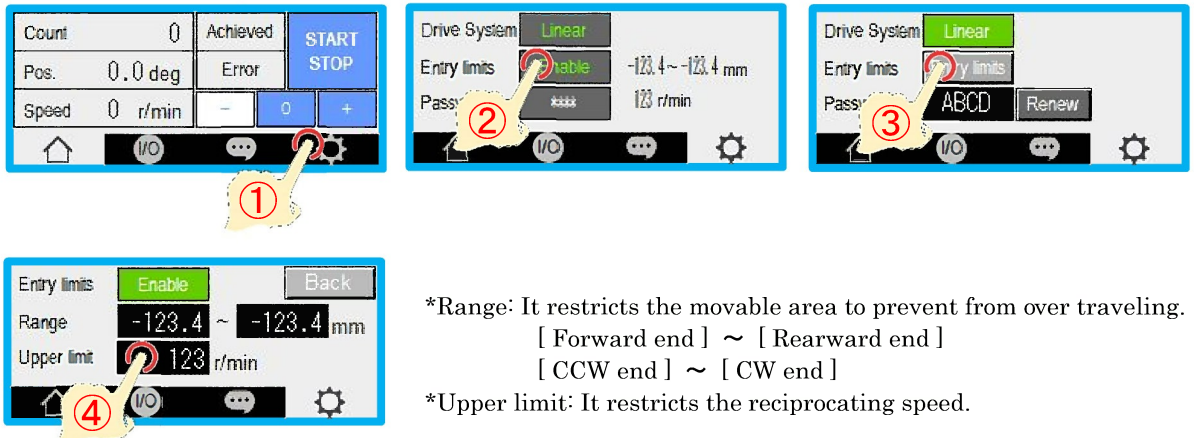

*Range: It restricts the movable area to prevent from over traveling.
 [Forward end] ~ [Rearward end]
 [CCW end] ~ [CW end]

*Upper limit: It restricts the reciprocating speed.

3.1.3 COORDINATE

CAUTION Make sure that the coordinate (moving direction) to input each position.

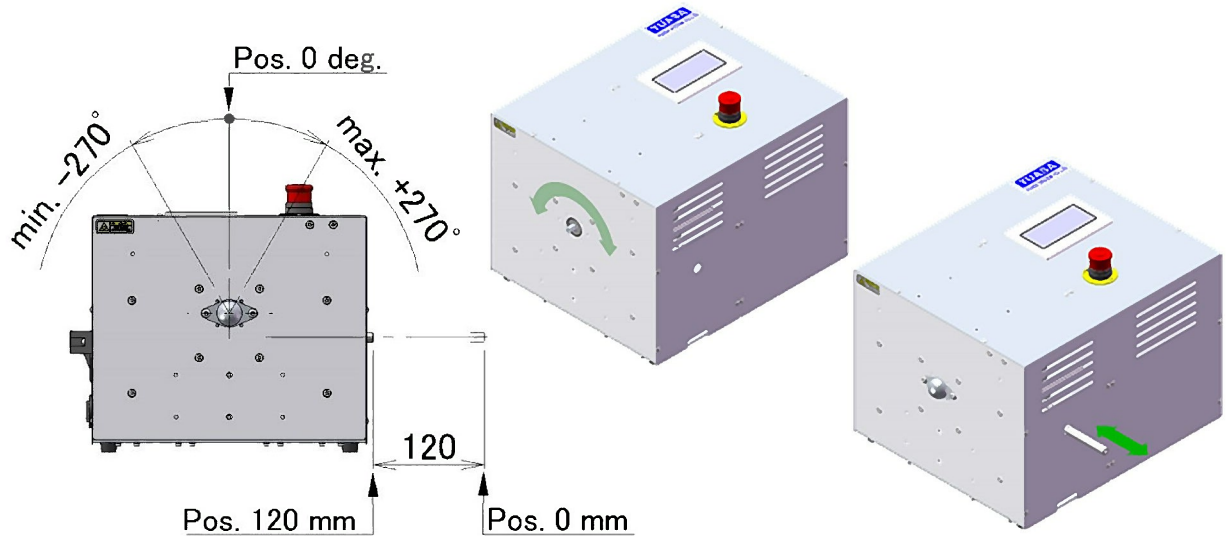

3.2 RECIPROCATING ANGLE or DISTANCE

- 1) Tap the “Pos.” button, the “setting” window will pop up.
- 2) Input the speed (set point), then tap the “ENT” button.
CAUTION Refer to a instruction manual and a specification of the testing jig.
- 3) Confirm each set point, then tap the “HOME” icon to return to the “HOME” screen.

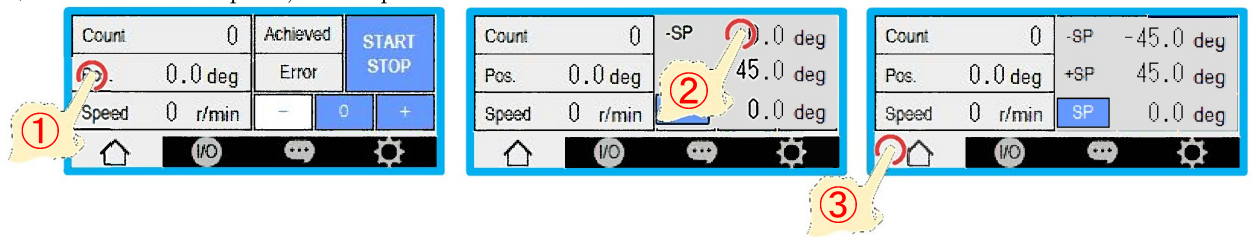

3.3 RECIPROCATING SPEED

- 1) Tap the “Speed” button, the “setting” window will pop up.
- 2) Input the speed (set point), then tap the “ENT” button.
CAUTION Refer to attached instruction manual and specification of the testing jig.
NOTICE Number shown on the screen is set value. Check present value with the stopwatch etc. because present value may change by load.
NOTICE The speed is in “r/min. (reciprocation per minute)”.
- 3) Confirm each set point, then tap the “HOME” icon to return to the “HOME” screen.

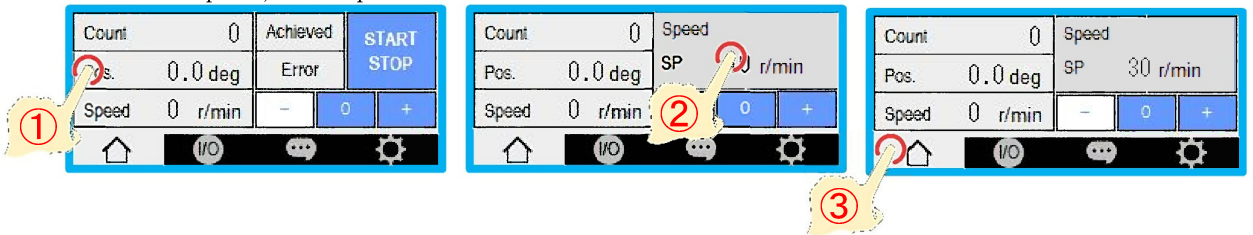

3.4 PRESET COUNTER

NOTE DMLHP will stop when the reciprocation times reaches to the target number.

- 1) Tap the “Count” button, the “setting” window will pop up.
- 2) Input the preset number (target number), then tap the “ENT” button.
- 3) Confirm each set point, then tap the “HOME” icon to return to the “HOME” screen.

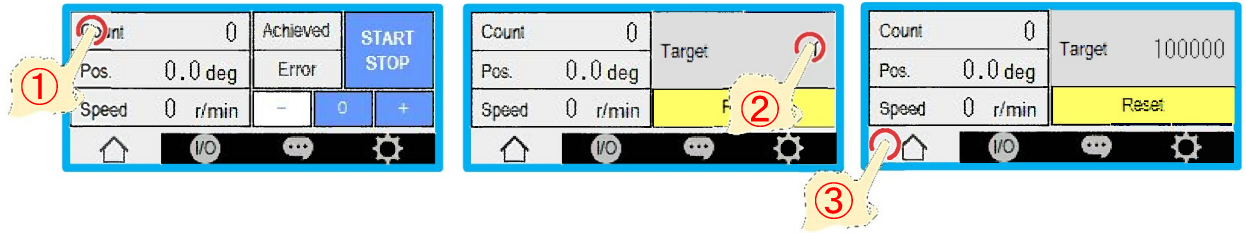

3.4.1 RESET COUNT

NOTE Change the target number or reset the present count to continue operation.

- 1) Tap the “Count” button, the “setting” window will pop up.
- 2) Press the “Reset” button two seconds, counter (Test Count) will reset to zero.
- 3) Tap the “HOME” icon to return to the “HOME” screen.

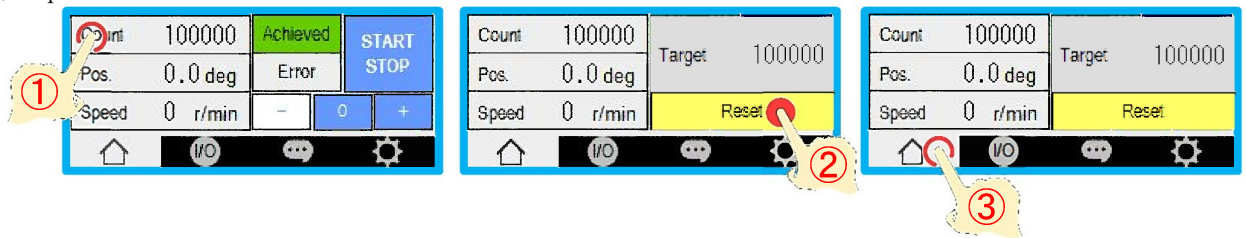

3.5 STOP SIGNAL

Can stop the endurance testing machine automatically if input any signal to the I/O terminal.

CAUTION Do not apply the voltage. Can connect only the dry contact.

3.5.1 SELECT CONTACT

Select the type “A-contact” or “B-contact” according to the testing equipment, the signal.

NOTE Shipment status is the “A-contact”.

- 1) Tap the “A” or “B” button, contact type will changes to another.

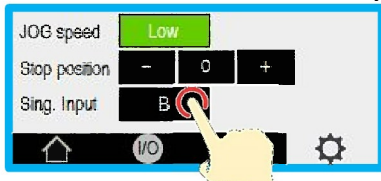

- ex. If the testing equipment input the signal with error.
⇒ “A”
- ex. If the testing equipment shut off the signal with error.
⇒ “B”
- ex. If connect the sample which turns on electricity with error.
⇒ “A”
- ex. If connect the sample which turns off electricity with error.
⇒ “B”

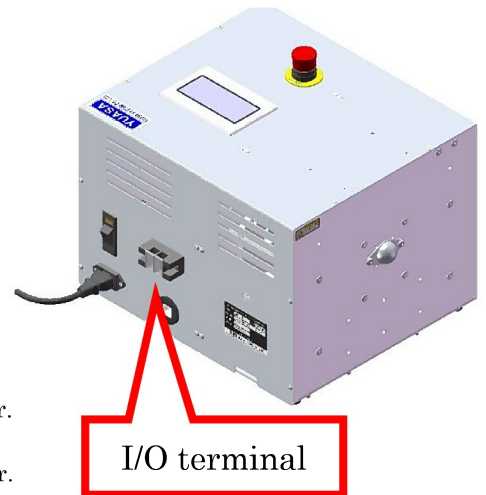

3.6 OPERATION

NOTICE All of set points can change anytime regardless of operation state.

INTERLOCK Cannot operate the endurance testing system without any cover for the test jig.

3.6.1 START

- 1) Tap the "START / STOP" button, the "confirmation" window will pop up.
- 2) Tap the "Start" button to start operation.

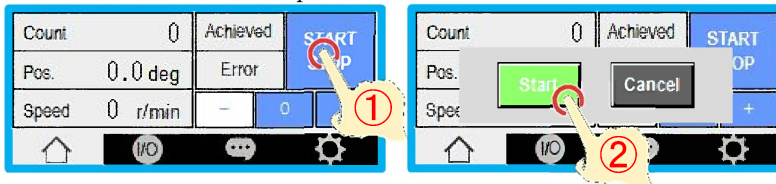

3.6.2 STOP

- 1) Tap the "START / STOP" button to stop operation.



3.6.2.1 STOP POSITION

Can select the stop position that the position to stop after finish a test.

- 1) Tap the "SETTING" icon to display the "SETTING" screen.
- 2) Select the stop position from "-" or "0" or "+".

NOTE Stop position [-]: DMLHP stop on the set position "-SP".

NOTE Stop position [0]: DMLHP stop on the center position between "-SP" and "+SP".

NOTE Stop position [+]: DMLHP stop on the set position "+SP".



3.6.3 JOG

- 1) Press the "JOG" button, DMLHP move slowly while keep pressing, then it automatically stop on each target position.

NOTE Target position [-]: DMLHP move to the set position "-SP".

NOTE Target position [0]: DMLHP move to the center position between "-SP" and "+SP".

NOTE Target position [+]: DMLHP move to the set position "+SP".

NOTE Can select the jogging speed from "Low" or "High" at the "SETTING" screen.



3.6.4 POSITIONING

- 1) Tap the "Pos." button, the "setting" window will pop up.
- 2) Input a position (set point), then tap the "ENT" button.
- 3) Tap the "SP" button to locate the output shaft to the set position.

NOTE DMLHP move in set reciprocating speed (same parameter as the "START" button).

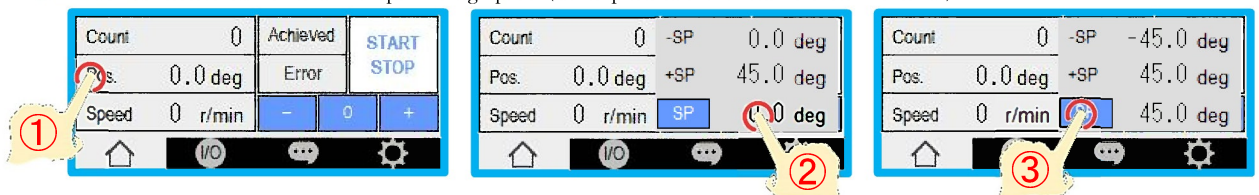

4. MAINTENANCE and INSPECTION

4.1 INSPECTION

This endurance testing machine is maintenance-free.

Change to the new one if some components will go break because of using condition or requirement.

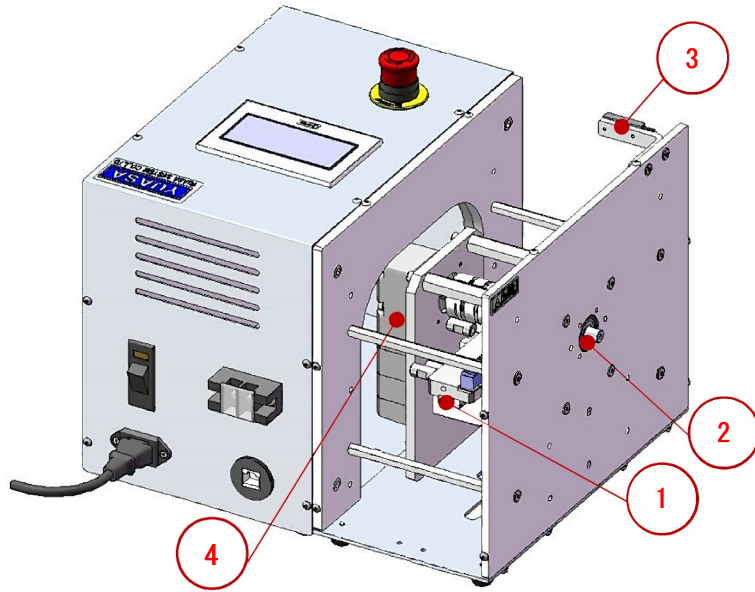

No	REGION	INSPECT	SCHEDULE
-	Exterior	Wipe or vacume out all debris.	Weekly
1	Linear Guide	Check it moves smoothly, with hand or low speed operation. (without wobble, noise and dirt)	Monthly
2	Driving Shaft	Check it moves smoothly, with hand or low speed operation. (without wobble, noise and dirt)	Monthly
3	Magnetic Proximity Switch	Check the endurance testing machine are not operated without the cover for the test jig.	Monthly
4	Motor Unit	Check it moves silently, without noise.	Monthly

Notice: Check the all items after a long-termstop.

No	NAME	TYPE	Num.	MANUFACTURE	NOTE
1	C-Lube Linear Way	MLF18C1R170HS1	1	IKO	
2	Rotary Reciprocating Shaft	ET105A003-002	1	YUASA SYSTEM	
3	Magnetic Proximity Switch	RS-1NO-1000	1	NA Co., Ltd.	
4	Motor	AZM46AK-FC20DA	1	Oriental motor	

4.1.1 PARTS LIST

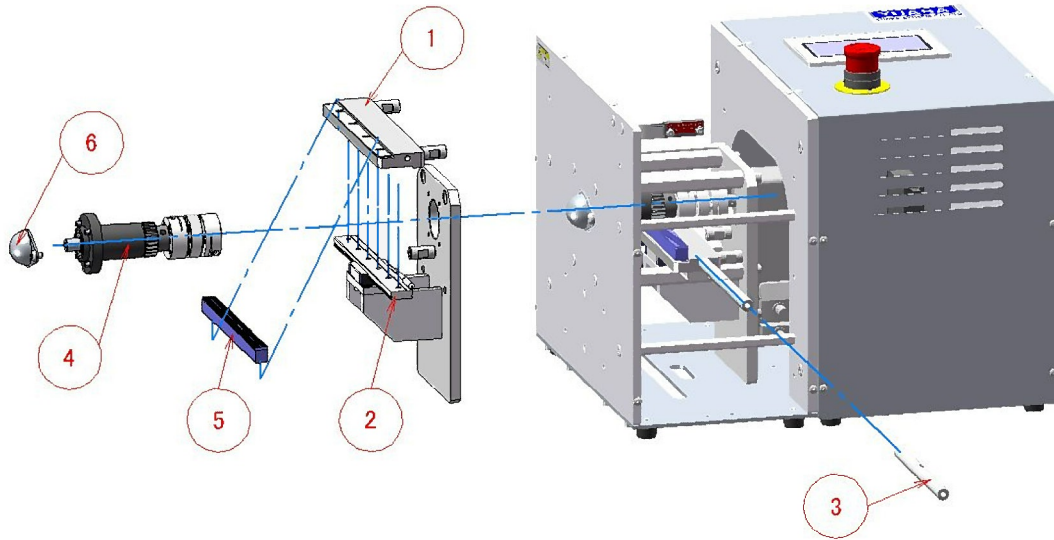

No	NAME	TYPE	Num.	MANUFACTURE	NOTE
1	Link Slider	ET104006R0001	1	YUASA SYSTEM	No.2 included
(2)	C-Lube Linear Way	MLF18C1R170HS1	1	IKO	
3	Linear reciprocating shaft	ET104003A0001	1	YUASA SYSTEM	
4	Rotary reciprocating shaft	ET105003A0002	1	YUASA SYSTEM	
5	Rack (Gear) repair kit	ET105003R0002	1	YUASA SYSTEM	
6	Shaft cover	ET501008A0001	1	YUASA SYSTEM	

4.2 ERROR MESSAGE and CORRECTIVE ACTION

Confirm the message that are shown on the “Message” view.

Correct each errors according to the instructions, below.

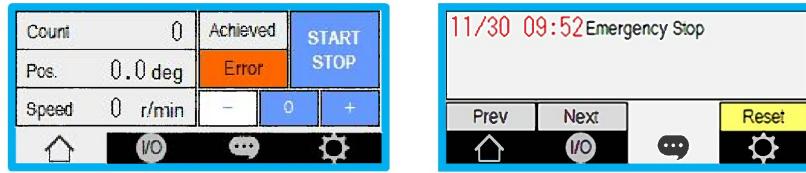

ERROR MESSAGE	CORRECTIVE ACTION
Emergency Stop	Release the lock of emergency stop button (turn the button).
Stop Signal A	Open the terminal, the circuit.
Stop Signal B	Close the terminal, the circuit.
Motor Error	Remove any error factors, debris or error of connector (Controller to Driving unit). NOTE Turn OFF the power supply switch, then turn ON after waiting 10 seconds.
Lost Cover	Attach the cover (for the test jig) to unlock the safety interlock.

4.3 TROUBLESHOOTING

If error is not shown on the “Message” view, refer to the troubleshooting as below.

WARNING Make sure the power is switched off and the machine is completely stopped before open each covers.

NOTE Confirm “I/O” screen as necessary.

PROBLEM	PROBLEM CAUSE	CORRECTIVE ACTION
Equipments will not boot up.	<ul style="list-style-type: none"> ·The plug isn't sticking. ·It isn't the 1 phase. 	<ul style="list-style-type: none"> ·Cofirm the electricity circuit.
Equipments will not operate.	<ul style="list-style-type: none"> · Value of preset count is less than present value. ·Position of the cam follower is zero. ·Magnetic proximity switch is dirty. ·Magnetic proximity switch is broken. 	<ul style="list-style-type: none"> ·Reset the preset value. ·Reset the counter, present value. ·Adjust the position of cam follower. ·Clean up the magnetic proximity switch. ·Change to the new one.
Strange motion or noise in operation.	<ul style="list-style-type: none"> ·Movement soud echoes in the machine. ·Equipments are dirty. ·Equipments are bloken. 	<ul style="list-style-type: none"> ·Check the source of sound. ·Check positional relation, the machine and jigs. ·Clean up equipments. ·Please contact us.

NOTE The case except the above, please contact us.

4.3.1 I/O CHECK

NOTE Can confirm each signal status with the I/O screen.

We may ask for the confirmation of the I/O screen to improve the problem.

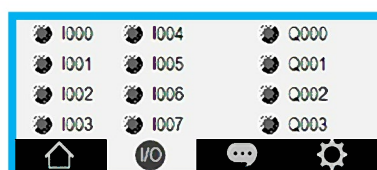

5. REMOTE CONTROL

5.1 OUTLINE

Can control the endurance testing system with PC (Local Area Network).

NOTE Should design application software according to basic format, below.

NOTE Can download the simple referenc software from URL, below.
(URL:)

5.2 FORMAT

5.2.1 BASIC FORM

Every messages consists of Header, Data and Footer.

NOTE In this system, every Headers and Footers are “#”.

ex. The message to read the “count, present value”: #RCOP#

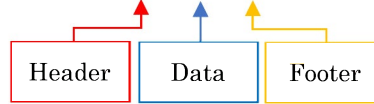

NOTE The endurance testing system communicates in decimal digit.

#RCOP# ↔ 35 82 67 79 80 35

5.2.2 REQUEST MESSAGES

Request Messages has the Read Messages and Write Messages.

Use each Read Messages to read each present value.

Use each Write Messages to write each set value.

• READ MESSAGES

There are seven kinds of Read Messages to read each information.

NAME	1	2	3	4	5	6
All Status	#	R	A	L	L	#
Count PV	#	R	C	O	P	#
Count SV	#	R	C	O	S	#
Speed PV	#	R	S	P	P	#
Speed SV	#	R	S	P	S	#
Operation Status	#	R	S	T	1	#
Error Status	#	R	S	T	2	#

NOTE PV: Present Value

NOTE SV: Set Value

NOTE All Status: Operation Status, Count PV and Speed PV

NOTE Operation Status: In-Operation or Non-Operation

• WRITE MESSAGES

There are three kinds of Write Messages to write each information.

NAME	1	2	3	4	5	6	7	8	9	10	11	12	13	14
Count SV	#	W	C	O	S	*	*	*	*	*	*	*	*	#
Speed SV	#	W	S	P	S	*	*	*	#					
Operation Status	#	W	S	T	1	*	#							

NOTE PV: Present Value

NOTE Input the number into “*”.

· Count SV: 00000000 ~ 99999999

· Speed SV: 010 ~ 120

· Operation Status: “0: Stop” or “1: Start”

5.2.3 RESPONSE MESSAGES

The endurance testing machine will output Response Message automatically according to Request Message.

NAME	1	2	3	4	5	6	7	8	9	10	11	12	13	14	15	16	17	18
All Status	#	R	A	L	L	*	*	*	*	*	*	*	*	*	*	*	*	#
Count PV	#	R	C	O	P	*	*	*	*	*	*	*	*	#				
Count SV	#	R	C	O	S	*	*	*	*	*	*	*	*	#				
Speed PV	#	R	S	P	P	*	*	*	#									
Speed SV	#	R	S	P	S	*	*	*	#									
Operation	#	R	S	T	1	*	#											
Error Status	#	R	S	T	2	*	*	*	*	#								
Count SV	#	W	C	O	S	*	*	*	*	*	*	*	*	#				
Speed SV	#	W	S	P	S	*	*	*	#									
Operation	#	W	S	T	1	*	#											

NOTE PV: Present Value

NOTE SV: Set Value

NOTE All Status: Operation Status, Count PV and Speed PV

ex. The Endurance testing machine is moving at 30 r/min. and reached the count to 999 reciprocations.

- a) Request: #RALL# ⇒ Response: #RALL100000999030#
- b) Request: #RST1# ⇒ Response: #RST11#
- c) Request: #RCOP# ⇒ Response: #RCOP00000999#
- d) Request: #RSPP# ⇒ Response: #RSPP030#

5.3 IP ADDRESS

Initial IP Address: 192.168.0.1

Initial Subnet Mask: 255.255.255.0

NOTE Can change IP Address and Subnet Mask freely.

- 1) Select the “Setting” screen.
- 2) Tap the arrow “▼” button. IP Address and Subnet Mask will be shown on the screen.
- 3) Tap the numeric display. The keypad will pop up.
- 4) Input number and tap the “ENT”.
- 5) Tap the “Renew” button. The endurance testing machine will restart the touch panel display.

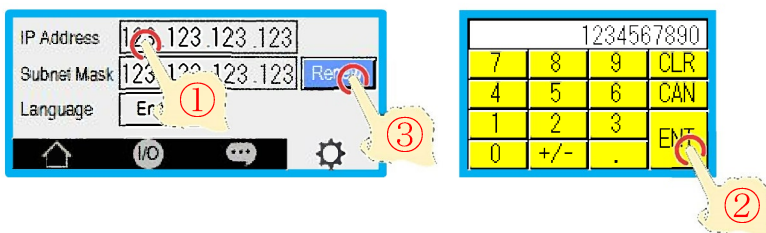



YouTube help to understand how to set up the testing jig.
Please cover the communication fee.

Quick Reference with Website

Add keywords into the address bar from our website to access the quick reference.



<http://www.yuasa-system.jp/en>



<http://www.yuasa-system.jp/manuals/ET000003M0003>

YUASA

YUASA SYSTEM CO., LTD.

~ Further Improve Reliability

<http://www.yuasa-system.jp> ~

KIBITSU FACTORY:	2292-1, Kibitsu, Kita-ku, Okayama-shi, OKAYAMA 701-1341, JAPAN	Tel. +81-86-287-9030 / Fax. +81-86-287-2298
TOKYO OFFICE:	3F, Shinbashi SN BLDG, 5-7-10, Shinmachi, Minato-ku, TOKYO 105-004, JAPAN	Tel. +81-3-3578-8515 / Fax. +81-3-3578-8516
OSAKA OFFICE:	8F, NLC Shin-Osaka Earth-BLDG, 5-1-3, Miyahara, Yokogawa-ku, Osaka-shi, OSAKA 532-003, JAPAN	Tel. +81-6-6394-8175 / Fax. +81-6-6397-2632

The Contents of the instruction manual may change to improve without notice.