

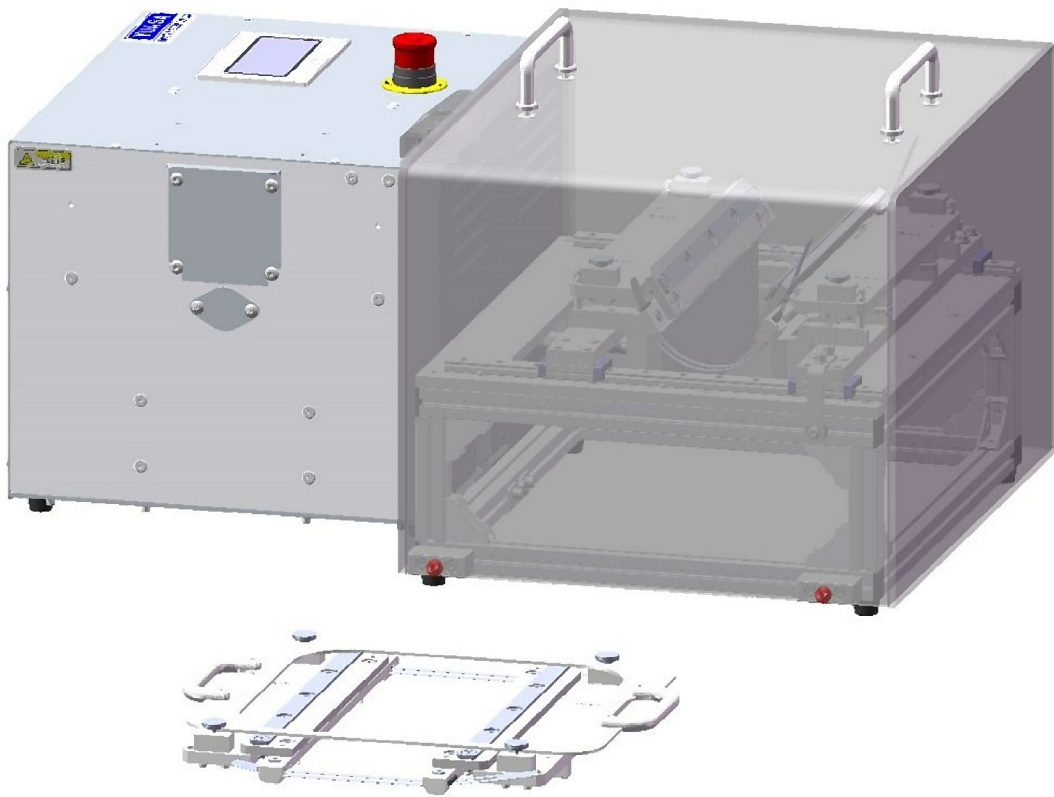

INSTRUCTION MANUAL TENSION-FREE FOLDING

ET254M002-010/02



Safety precaution are classified into five categories

- WARNING** : Death or serious injury may result from not following product installation instruction.
- CAUTION** : Minor injury, as well as damage to the product may result from not following product instruction.
- NOTICE** : Inaccurate data may result from not following the test instructions.
- NOTE** : General knowledge.
- INTERLOCK** : Effect of the interlock system for safety.

- INTERLOCK** : Install the safety cover and prevent access to any moving parts.
- WARNING** : Installing, operating, maintaining or inspecting must be carried out by skilled and professional engineers.
- WARNING** : Make sure to tighten each screws as described in this manual.
- WARNING** : Make sure the Emergency Stop Button is maked work, and the machine is completely stopped before adjust the testing condition and change the part.
- WARNING** : Make sure the power is switched off, and the machine is completely stopped before carrying out maintenance and inspection.
- WARNING** : Do not use products beyond its capacity as specified in the specification.
- WARNING** : Do not remodel.
- CAUTION** : Do not change installation environment (temperature and humidity) rapidly.
- CAUTION** : Isolate the machine from sunlight.
- CAUTION** : Isolate the machine from any noise.
- CAUTION** : Isolate the machine from any dust.
- CAUTION** : Isolate the machine from large vibration.
- CAUTION** : Immediately stop the machine upon any sign of abnormal operation.
- NOTICE** : Make sure to tighten the screws as described in the manual.
- NOTE** : In some cases, illustrations with different shapes may be included.
- NOTE** : In some cases, a description different from the your equipment may be included.
- NOTE** : The scraps should be disposed as general waste by skilled professionals.

- CONTENTS -

1. INTRODUCTION	
1.1 OVERVIEW	1-1
1.2 STRUCTURE and COMPONENT	1-1
1.3 INSTALLATION	1-2
3. SETTING of TESTING CONDITON	
3.1 YES/NO CHART to CONFIRM SETTING STEP	3-1
3.1 A: Set up folding radius with default reciprocating distance	3-1
3.1 B: Set up testing condition follow to folding radius	3-4
3.1 C: Set up testing condition follow to the sample and folding radius	3-7
3.2 PUT OUT/ PUT ON THE CARTRIDGE	3-10
3.2.1 PUT OUT THE CARTRIDGE	3-10
3.2.2 PUT ON THE CARTRIDGE	3-11
3.3 SAFETY COVER	3-12
3.3.1 ATTACH THE COVER on THE TESTING JIG	3-12
4. MAINTENANCE and INSPECTION	
4.1 INSPECTION	4-1
4.1.1 CHANGE TILT CONTROLLERS	4-2

[- NOTICE -]

We make absolutely sure about the contents of this user manual.
However, if you have some questions or find some incorrect, please contact us.

1. INTRODUCTION

1.1 OVERVIEW

Sample's Size	Thickness : max. 1 mm Width : max. 224 mm
Bending Angle	0~180°
Bending Radius	0~22 mm (* Bending Angle: 0⇔180°)
Rec. Distance	0~±60 mm
Rec. Speed	Max. 90 rec./min
Mass	DLDM111LH : About 17 kg (37.5 lb) Test Jig : About 8 kg (15.5 lb) Cover : About 4 kg (8.5 lb)
Installation Environment	Temp. : +5~+40° C (41~104° F) Humi. : 15~98%RH (No Condensation)

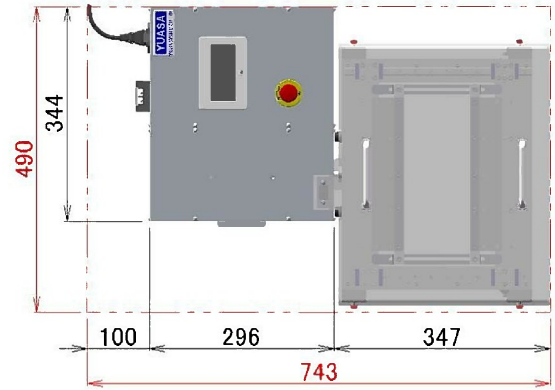

1.2 STRUCTURE and COMPONENT

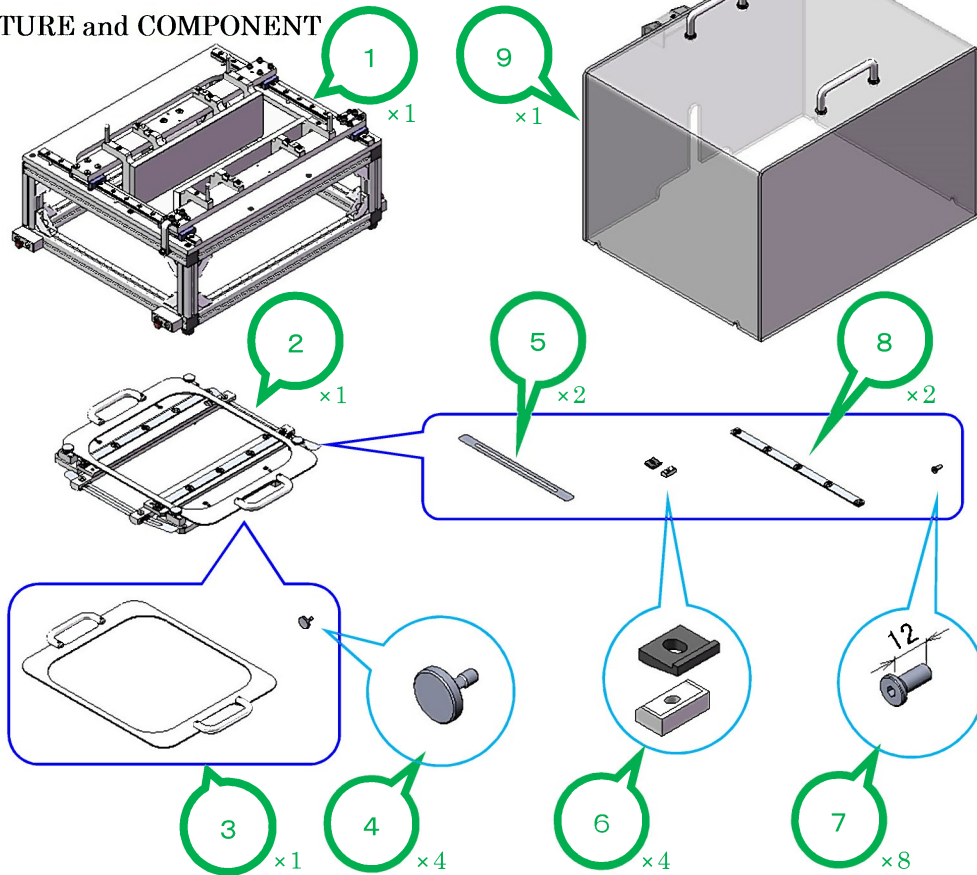

No	NAME	TYPE	MANUFACTURE (MATERIAL)	NOTE
1	Basic unit, tension-free folding	ET254A002-010	YUASA SYSTEM	
2	Cartridge	ET254A007-001	YUASA SYSTEM	
3	Handling Plate	ET200P214-005	YUASA SYSTEM	
4	Knurled thumb screw	RNCB4-5-10	MISUMI	
5	Tilt controller	ET200P165-006	YUASA SYSTEM	
6	Support, tilt controller	ET200P170-002+P170-006	YUASA SYSTEM	
7	Extra low head cap screw	CBSM5-12	MISUMI	
8	Clamping plate	ET200P005-045+P006-006	YUASA SYSTEM	
9	Safety Cover	ET500A003-025	YUASA SYSTEM	For Test Jig

NOTE Explain words in this instruction manual.

- Tilt Clamp : The clamp base which swings freely
- Tilt Controller : Clamp bases which swings follow to tilt controllers.

1.3 INSTALLATION [Tool: 3 mm Hexagon Bar Wrench]

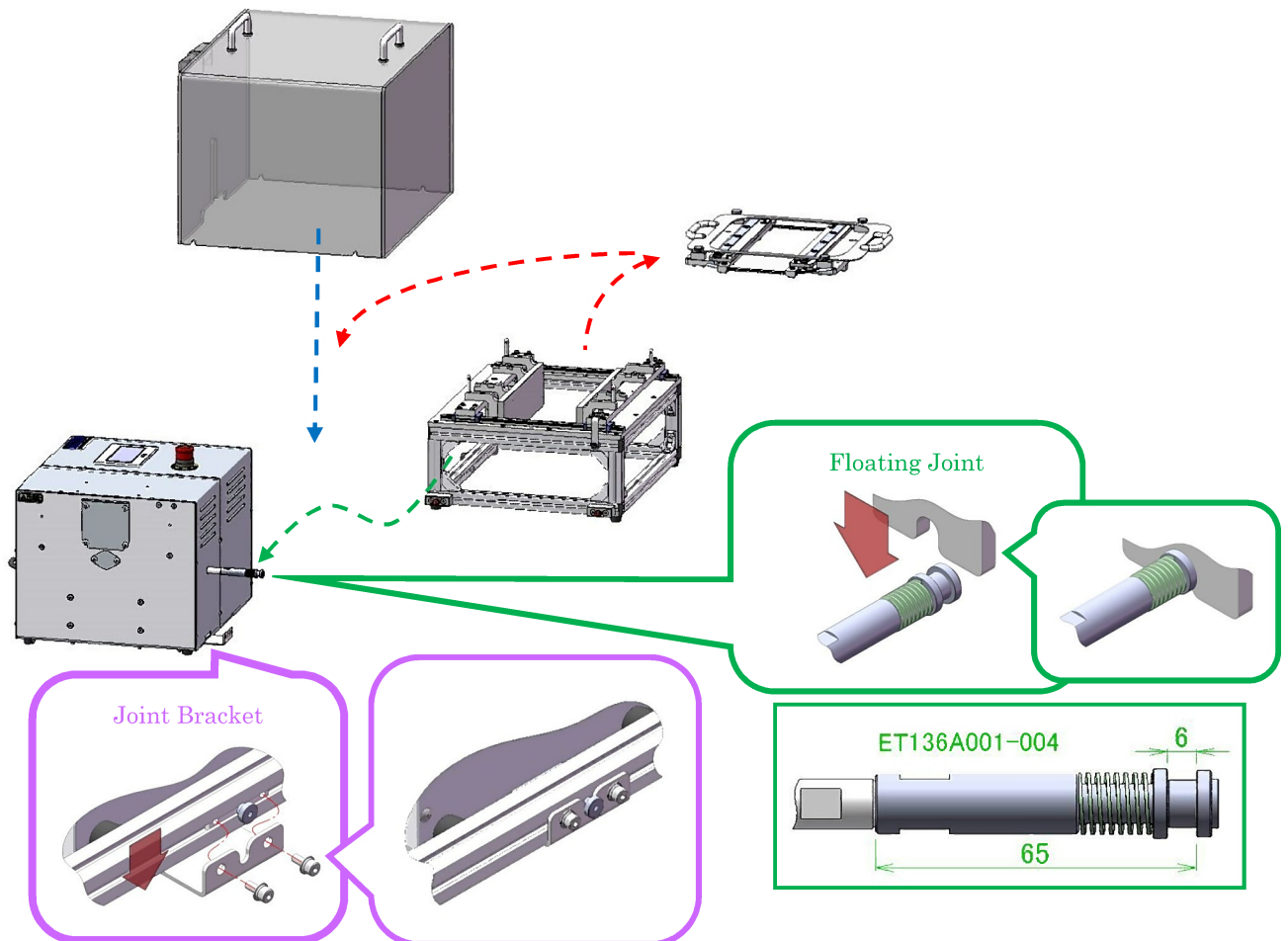

1. Confirm the floating joint is [ET136A001-004] that is attached on DLDM111LH, output shaft.
2. Put out the cartridge from the test jig (Refer to “3.2.1 PUT OUT THE CARTRIDGE” for detail).
- ▶ 3. Hold the test jig to DLDM111LH and set it down slowly.
- ▶ 4. Put the slider (Test Jig) on the floating joint.
- ▶ 5. Confirm the floating joint is inserted to the slider.
- ▶ 6. Fix the test jig to the joint bracket with screws. [Tool: 3 mm Allen Wrench]
 - NOTE Washer assembled cap screw: M4x10, 2 sets
 - CAUTION Tightening torque: 3.0 N·m (do not over tighten screws)
- ▶ 7. Attach the cover to the test jig and check the movement, DLDM111LH and the test jig (Refer to “3.3 SAFETY COVER” for detail).
 - INTERLOCK Cannot operate DLDM111LH when the safety cover is open.
- ▶ 8. Locate the moving slider to rearmost position.
 - NOTE The test jig become same as shipping condition.
9. Remove the cover from the test jig.
- ▶ 10. Put on the cartridge onto the test jig (Refer to “3.2.2 PUT ON THE CARTRIDGE” for detail).

3. SETTING of TEST CONDITIONS

3.1 YES/NO CHART to CONFIRM SETTING STEP

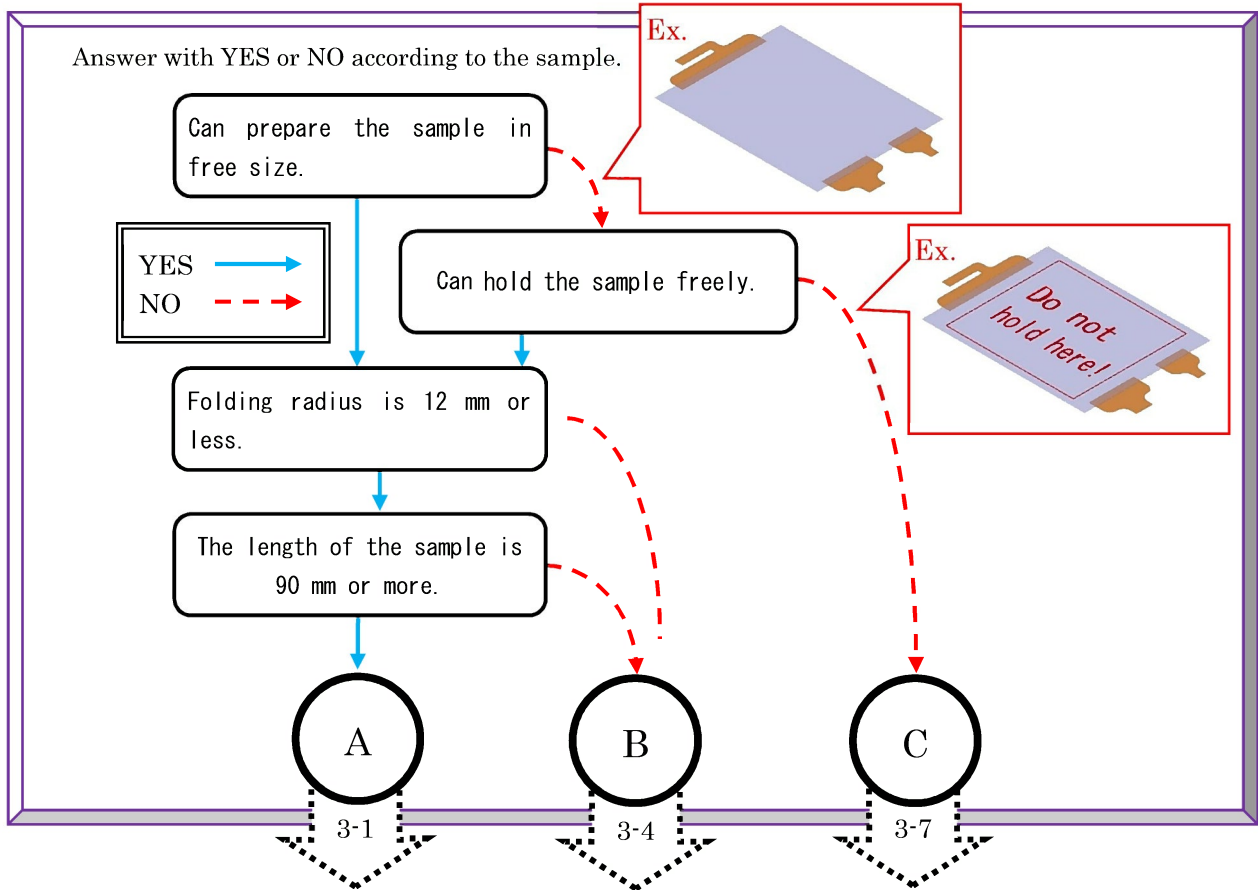

3.1 A: Set up folding radius in 10 mm or less with same reciprocating distance. [Tool: 3 mm Allen Wrench]

CAUTION Cannot move the driving shaft, DLDM111LH, with hand when the driving shaft located in full-forward or rearmost position. Move the driving shaft with operation panel other than full-forward or rearmost position.

NOTE The manual explain steps with case of “Folding Radius: 7.5 mm, Holden Space: 5 mm”.

1) Prepare the sample.

NOTICE Can check the length of the sample for test condition as below.

- Folding Radius : $0 \leq R \leq 12$
- Holden Space : α_1, α_2

◆ Length of the sample: $56 + 2R + \alpha_1 + \alpha_2$

ex. Folding Radius: 7.5 mm (Holden Space: 5 mm)

$\text{Sample} = 56 + 2 \times 7.5 + 5 + 5$
 $= 81 \Rightarrow \text{Prepare the sample in 81 mm or more.}$

2) Confirm the reciprocating distance (DLDM111LH) is set in ±40 mm.

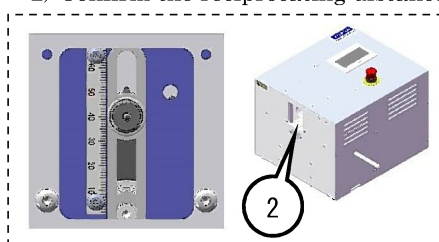

- ▶ 3) Loosen two screws (to fix the tilt controller) and slack off tilt controllers.
 - NOTE Refer to “4.1.1 CHANGE TILT CONTROLLERS”, if tilt controllers are removed from the test jig.
- ▶ 4) Loosen two screws (to fix the fixed slider) to move the fixing slider freely.

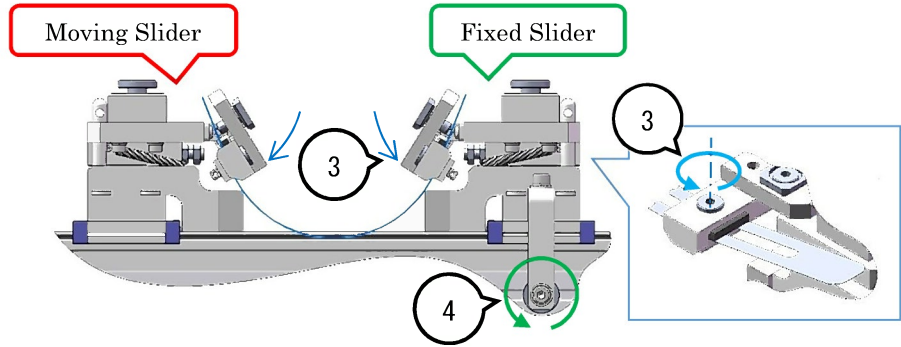

- 5) Locate the moving slider to full forward position.
- ▶ 6) Adjust the fixed slider to folding radius (distance between both sliders) [2R] as below.
 - NOTE Put something (the spacer or the block gauge) between both sliders, setting become easy.
- ▶ 7) Fix the fixed slider with two screws.
 - CAUTION Tightening torque: 3.0 N·m (do not over tighten screws)

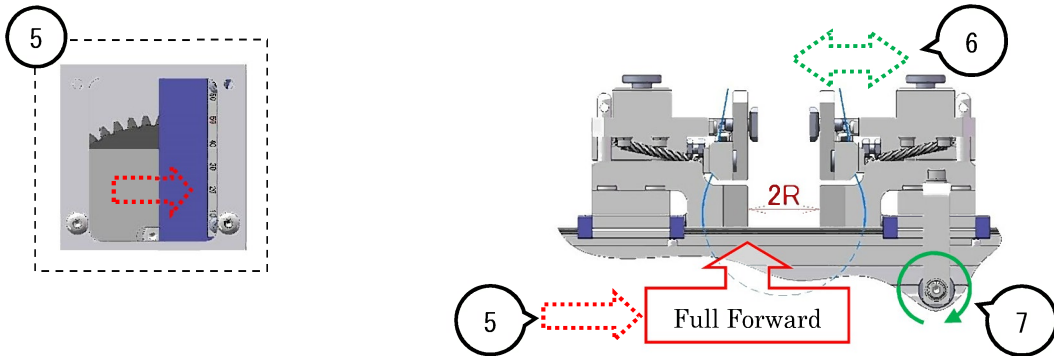

- 8) Locate the moving slider to rearmost position.
- ▶ 9) Pull tilt controllers (plate springs) to make clamps stay horizontally.
- ▶ 10) Fix tilt controllers (the moving slider's side) with two screws.
 - CAUTION Tightening torque: 3.0 N·m (do not over tighten screws)
 - NOTE It is not necessary to equalize each margins of tilt controllers.

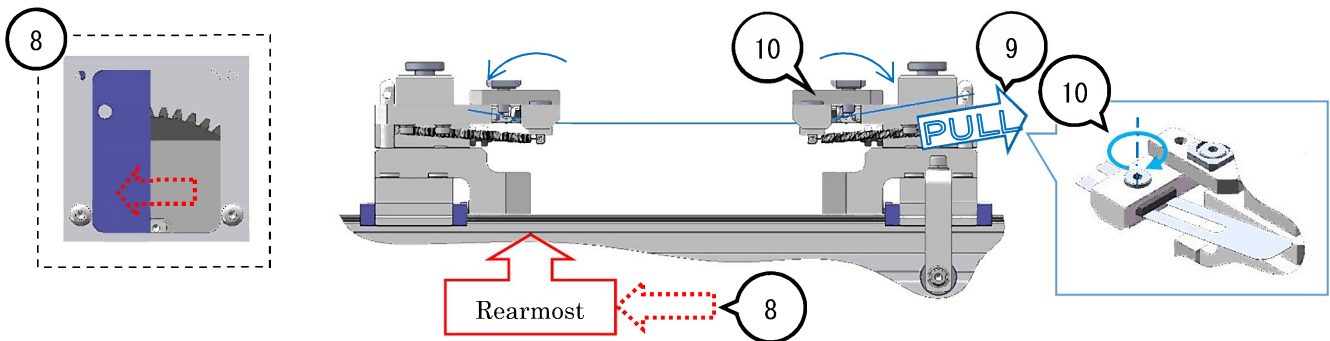

11) Set the sample to tilt clamps with clamps or something, adhesive tapes.

NOTE The huge force is not necessary to set the sample because the sample has no tension.

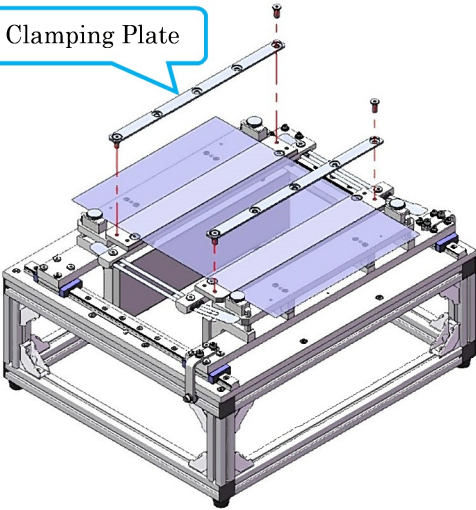

The diagram shows a metal frame with a blue clamping plate mounted on top. A sample is placed on the plate, and it is held in place by several clamps. A callout box labeled "Clamping Plate" points to the blue plate.

◆ Set with clamps

- The adhesive does not stick on the sample
- Surface of the sample is oily or dirty or ...
- Etcetera...

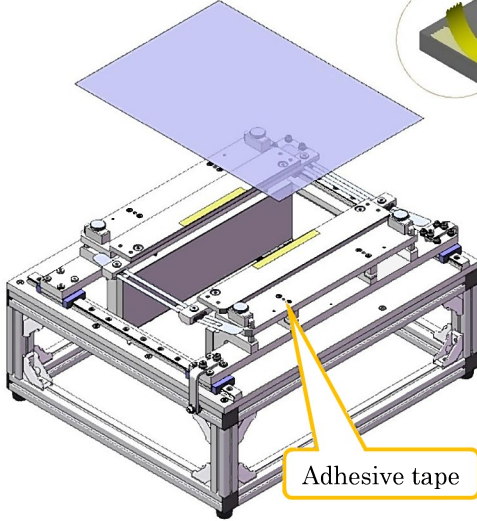

The diagram shows the same metal frame, but instead of a clamping plate, a yellow adhesive tape is used to secure the sample. A callout box labeled "Adhesive tape" points to the yellow tape. An inset in the top right corner shows a close-up of the tape being applied to the sample.

◆ Set with adhesive tapes

- The folding radius is too small.
- The sample will break with clamps.
- Set samples of various thickness in same time.
- Etcetera...

NOTICE Tightening torque varies according to the sample or test condition.

CAUTION If tighten screws with huge torque, the plate becomes curve then cannot pinch the sample.

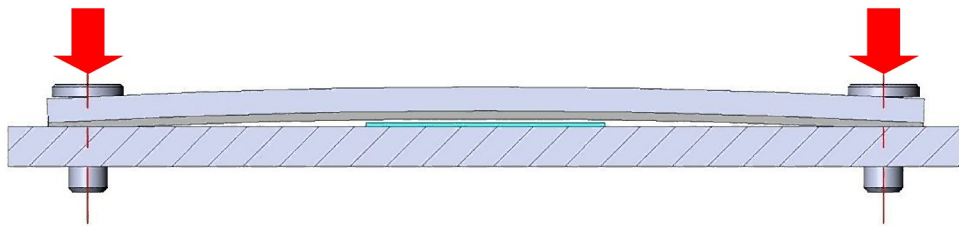

12) Check interference each components with low speed or hand moving.

INTERLOCK Cannot operate equipment with the operation panel whenever the safety cover opened.

3.1 B: Set up testing condition follow to folding radius. [Tool: 3 mm Allen Wrench]

CAUTION Cannot move the driving shaft, DLDM111LH, with hand when the driving shaft located in full-forward or rearmost position. Move the driving shaft with operation panel other than full-forward or rearmost position.

NOTE The manual explain steps with case of “Folding Radius: 20 mm, Holden Space: 5 mm”.

1) Calculate and check test condition.

NOTICE Reciprocating Distance

- Folding Radius: $0 \leq R \leq 22$

◆ Reciprocating Distance : $0.77R + 29.23 \leq st. \leq 93 - 2R$

ex. Folding Radius: 20 mm

$$0.77 \times 20 + 29.23 \leq st. \leq 93 - 2 \times 20$$

$$44.63 \leq st. \leq 53 \Rightarrow \text{Adjust reciprocating distance to } \pm 44.63 \sim 53 \text{ mm.}$$

* In this case, presume reciprocating distance to ± 50 mm.

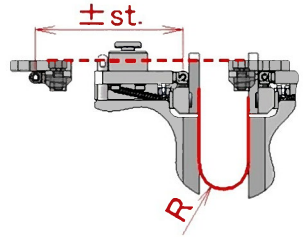

2) Prepare the sample.

NOTICE Can check the length of the sample for test condition as below.

- Folding Radius : $0 \leq R \leq 22$
- Reciprocating Distance : $\pm st.$
- Helden Space : α_1, α_2

◆ Length of the sample: $2st. + 2R - 24 + \alpha_1 + \alpha_2$

ex. Folding Radius: 20 mm (Clamped Space: 5 mm)

$$\text{Sample} = 2 \times 50 + 2 \times 20 - 24 + 5 + 5$$

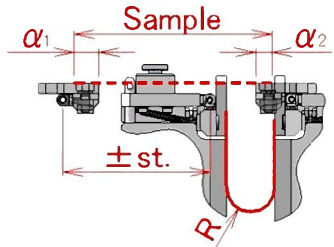
$$= 126 \Rightarrow \text{Prepare the sample in 126 mm or more.}$$

3) Adjust the reciprocating distance (DLDM111LH) to ± 50 mm.

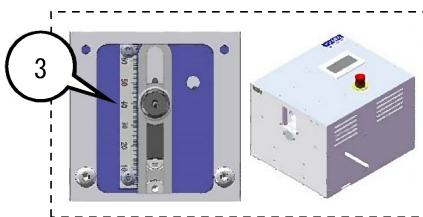

- ▶ 4) Loosen two screws (to fix the tilt controller) and slack off tilt controllers.
 - NOTE Refer to “4.1.1 CHANGE TILT CONTROLLERS”, if tilt controllers are removed from the test jig.
- ▶ 5) Loosen two screws (to fix the fixed slider) to move the fixing slider freely.

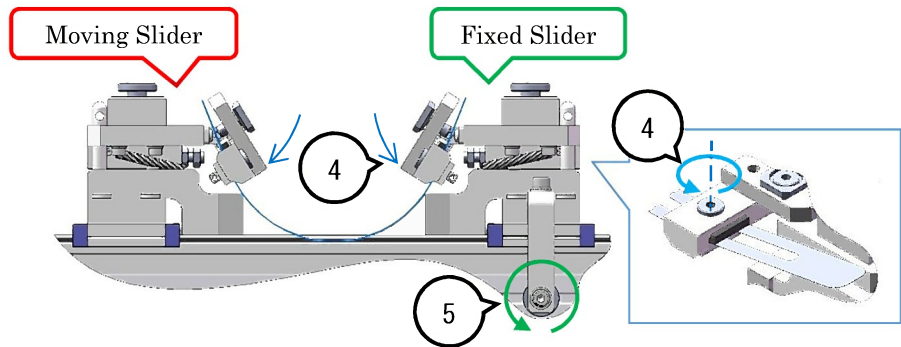

- 6) Locate the moving slider to full forward position.
- ▶ 7) Adjust the fixed slider to folding radius (distance between both sliders) [2R] as below.
 - NOTE Put something (the spacer or the block gauge) between both sliders, setting become easy.
- ▶ 8) Fix the fixed slider with two screws.
 - CAUTION Tightening torque: 3.0 N·m (do not over tighten screws)

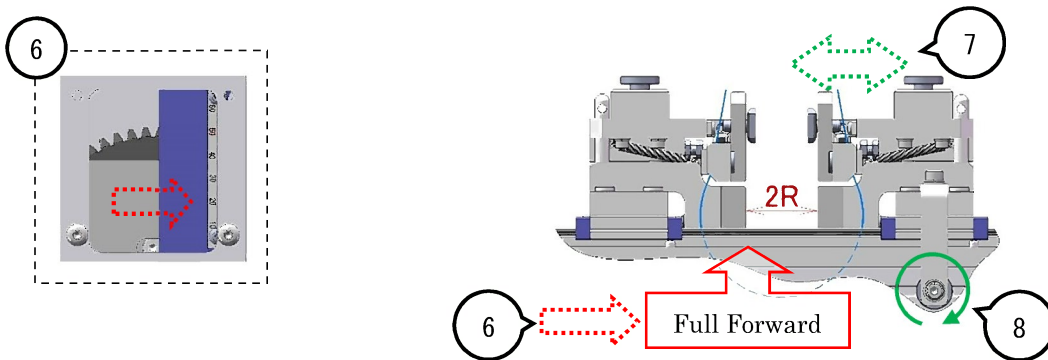

- 9) Locate the moving slider to rearmost position.
- ▶ 10) Pull tilt controllers (plate springs) to make clamps stay horizontally.
- ▶ 11) Fix tilt controllers (the moving slider's side) with two screws.
 - CAUTION Tightening torque: 3.0 N·m (do not over tighten screws)
 - NOTE It is not necessary to equalize each margins of tilt controllers.

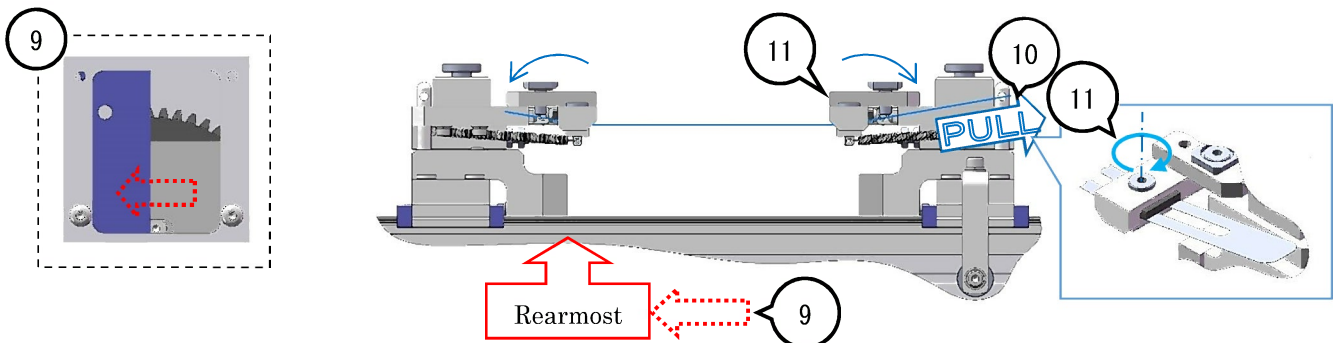

* Units of weights and measures shall be expressed in terms of the metric system (kg & mm) *

12) Set the sample to tilt clamps with clamps or something, adhesive tapes.

NOTE The huge force is not necessary to set the sample because the sample has no tension.

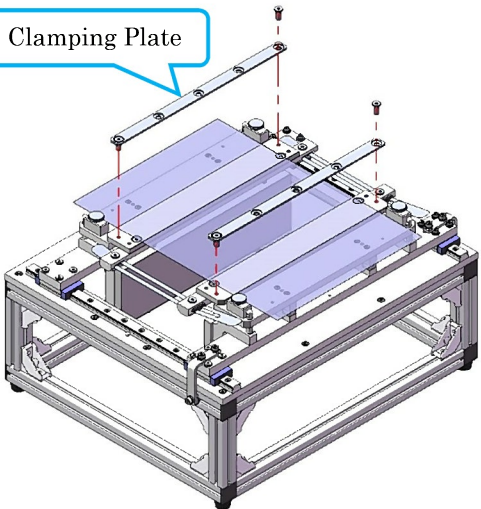

The diagram shows a metal frame with a blue clamping plate mounted on top. A sample is placed on the plate, and it is held in place by several clamps. A callout box labeled 'Clamping Plate' points to the blue plate.

◆Set with clamps

- The adhesive does not stick on the sample.
- Surface of the sample is oily or dirty or ...
- Etcetera...

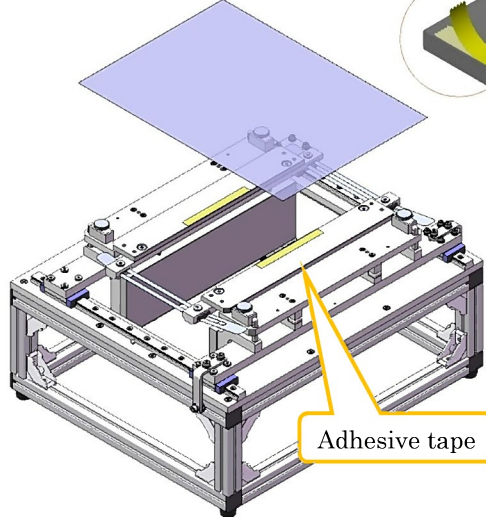

The diagram shows the same metal frame with a blue clamping plate. Instead of clamps, yellow adhesive tapes are used to secure the sample. A callout box labeled 'Adhesive tape' points to one of the tapes. An inset in the top right shows a close-up of the tape being applied to the sample.

◆Set with adhesive tapes

- The folding radius is too small.
- The sample will break with clamps.
- Set samples of various thickness in same time.
- Etcetera...

NOTICE Tightening torque varies according to the sample or test condition.

CAUTION If tighten screws with huge torque, the plate becomes curve then cannot pinch the sample.

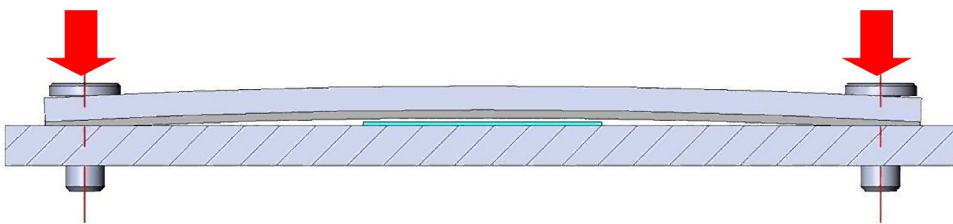

13) Check interference each components with low speed or hand moving.

INTERLOCK Cannot operate equipment with the operation panel whenever the safety cover opened.

3.1 C: Set up testing condition follow to the sample and folding radius. [Tool: 3 mm Allen Wrench]

CAUTION Cannot move the driving shaft, DLDM111LH, with hand when the driving shaft located in full-forward or rearmost position. Move the driving shaft with operation panel other than full-forward or rearmost position.

NOTE The manual explain steps with case of “Testing Area: 110 mm, Folding Radius: 15 mm, Holden Space: 5 mm”.

NOTE Testing area: The length between a couple of holden space.

NOTE Excess length: The length of straight area that will not change when the sample is folded.

1) Calculate and check excess length.

NOTICE Excess length

- Testing Area : L
- Excess Length : $8(\times 2)$
- Folding Radius: $0 \leq R \leq 22$

◆ Testing Area: $L = \pi R + 2\beta$

ex. Testing Area: 110 mm, Folding Radius: 15 mm

$$110 = \pi \times 15 + 2 \times \beta$$

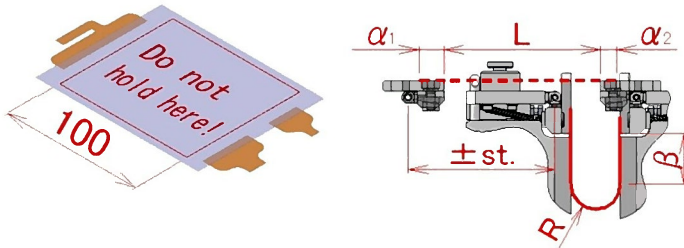
$$\beta = 31.44 \Rightarrow \text{Substitute } \beta = 31.44 \text{ for a following calculating formula.}$$

2) Calculate and check reciprocating distance.

NOTICE Reciprocating Distance

- Excess Length : $8(\times 2)$
- Folding Radius : $0 \leq R \leq 22$
- Reciprocating Distance : $\pm st.$

◆ Reciprocating Distance: $0.77R + 29.23 \leq st. = 6 + 0.57R + \beta \leq 93 - 2R$

ex. Testing Area: 110 mm, Excess Length: 31.44 mm, Folding Radius: 15 mm

$$0.77 \times 15 + 29.23 \leq st. = 6 + 0.57 \times 15 + 31.44 \leq 93 - 2 \times 15$$

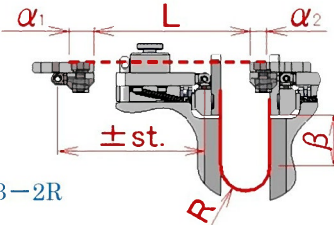
$$40.78 \leq st. = 45.99 \leq 63 \Rightarrow \text{Adjust reciprocating distance to } \pm 45.99 \text{ mm.}$$

3) Prepare the sample.

4) Adjust the reciprocating distance (DLDM111LH) to $\pm 45.99 \text{ mm}$ ($\pm 46 \text{ mm}$).

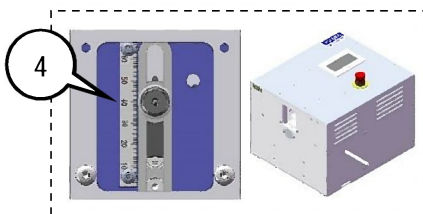

- 5) Loosen two screws (to fix the tilt controller) and slack off tilt controllers.

NOTE Refer to “4.1.1 CHANGE TILT CONTROLLERS”, if tilt controllers are removed from the test jig.

- 6) Loosen two screws (to fix the fixed slider) to move the fixing slider freely.

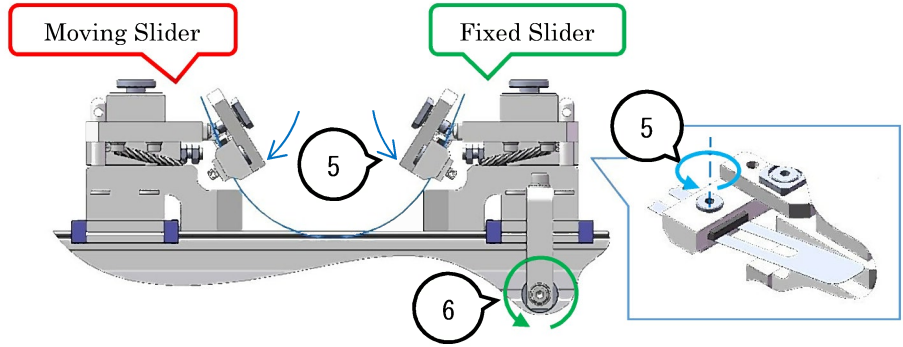

- 7) Locate the moving slider to full forward position.

- 8) Adjust the fixed slider to folding radius (distance between both sliders) $2R$ as below.

NOTE Put something (the spacer or the block gauge) between both sliders, setting become easy.

- 9) Fix the fixed slider with two screws.

CAUTION Tightening torque: $3.0 \text{ N}\cdot\text{m}$ (do not over tighten screws)

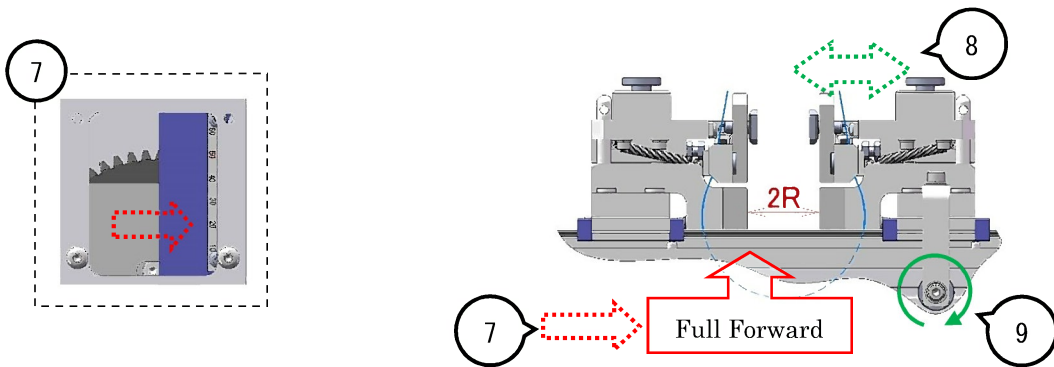

- 10) Locate the moving slider to rearmost position.

- 11) Pull tilt controllers (plate springs) to make clamps stay horizontally.

- 12) Fix tilt controllers (the moving slider's side) with two screws.

CAUTION Tightening torque: $3.0 \text{ N}\cdot\text{m}$ (do not over tighten screws)

NOTE It is not necessary to equalize each margins of tilt controllers.

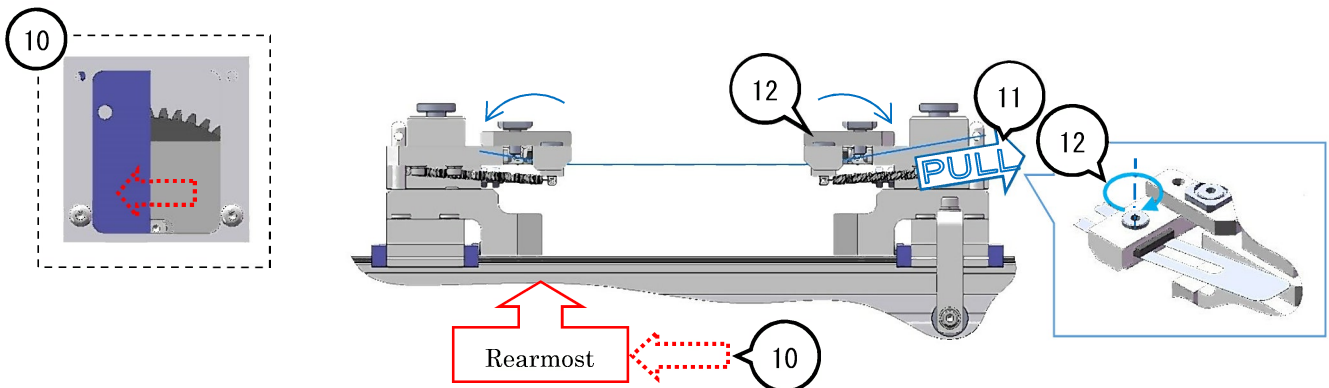

13) Set the sample to tilt clamps with clamps or something, adhesive tapes.

NOTE The huge force is not necessary to set the sample because the sample has no tension.

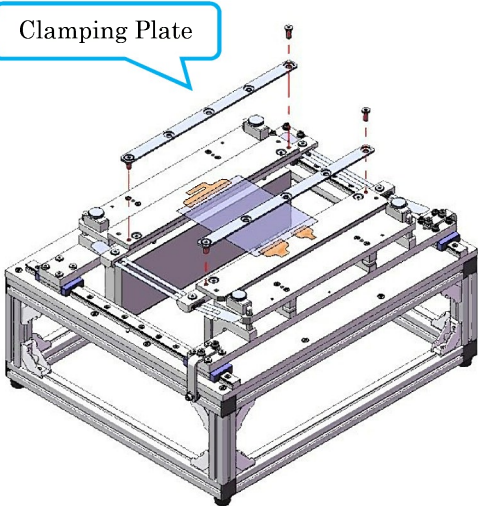

◆ Set with clamps

- The adhesive does not stick on the sample.
- Surface of the sample is oily or dirty or ...
- Etcetera...

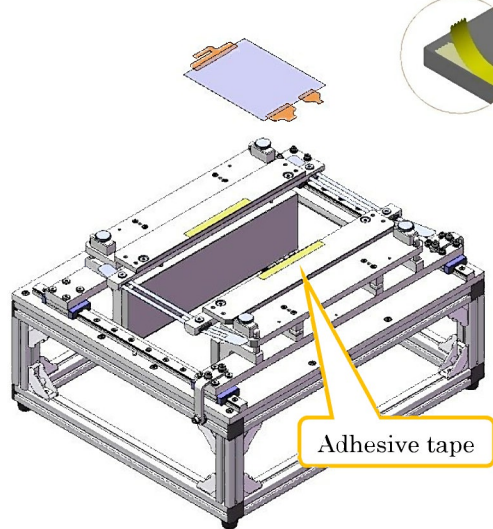

◆ Set with adhesive tapes

- The folding radius is too small.
- The sample will break with clamps.
- Set samples of various thickness in same time.
- Etcetera...

NOTICE Tightening torque varies according to the sample or test condition.

CAUTION If tighten screws with huge torque, the clamp becomes curve then cannot pinch the sample.

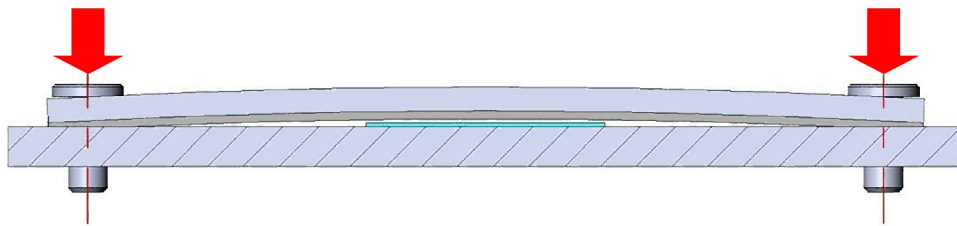

14) Check interference each components with low speed or hand moving.

INTERLOCK Cannot operate equipment with the operation panel whenever the safety cover opened.

3.2 PUT OUT/ PUT ON THE CARTRIDGE [TOOL: - - -]

Can remove samples together with the test jig, the cartridge, and reset it to continue test.

- Observe samples with the micro-scope repeatedly until tested number will reach to the target number.
- Change the testing method. (Ex. Folding, Folding & Pressing, Stretching, ...)
- Etcetera.

3.2.1 PUT OUT THE CARTRIDGE [TOOL: - - -]

1. Loosen every knurled-thumb-screws (about 3 rotation).

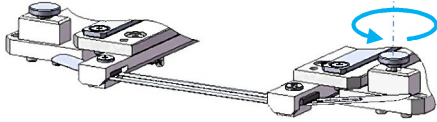

2. Insert the handling plate between the test jig and knurled-thumb-screws.

CAUTION Remove knurled-thumb-screws if the handling plate interfere with samples or something.

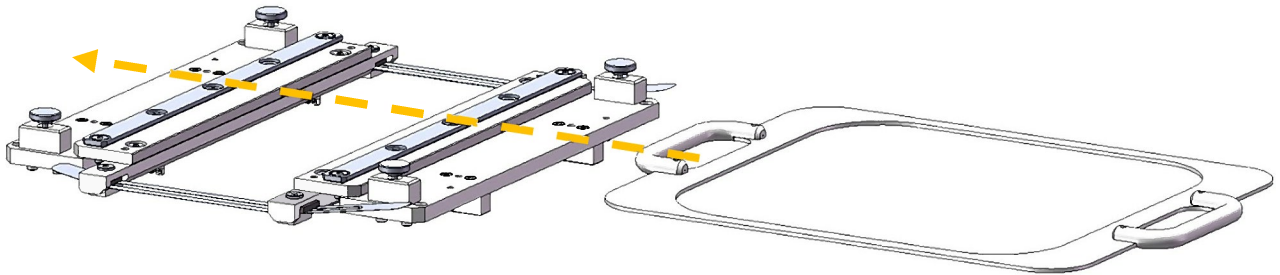

3. Tighten knurled-thumb-screws to fix the holding plate, the cartridge.

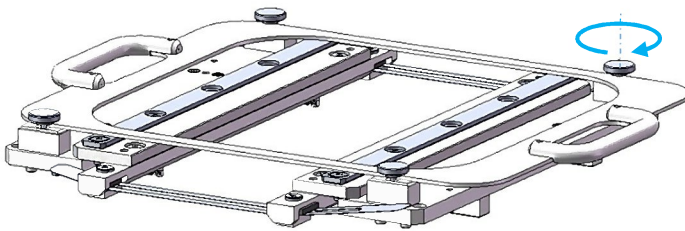

4. Hold handles and lift up the cartridge.

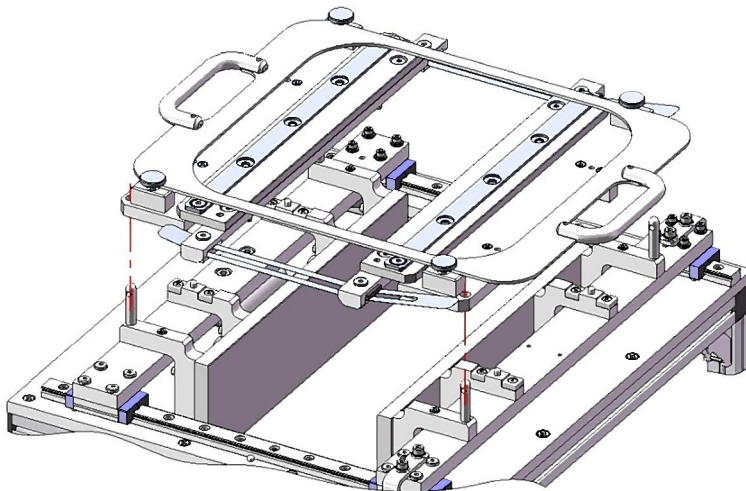

3.2.2 PUT ON THE CARTRIDGE [TOOL: - - -]

1. Locate the cartridge with rough-guide-pins, and put it on the test jig.

NOTE Loosen knurled-thumb-screws carefully if cannot locate the cartridge to rough-guide-pins.

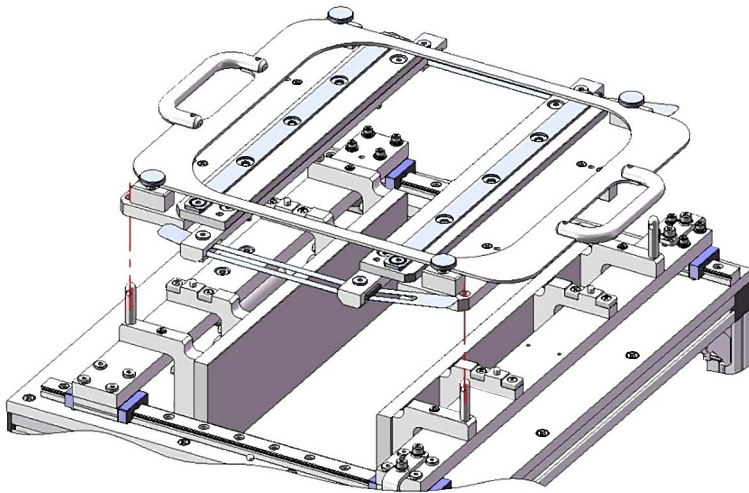

2. Loosen knurled-thumb-screws, and remove the handling plate.

CAUTION Remove knurled-thumb-screws if the handling plate interfere with samples or something.

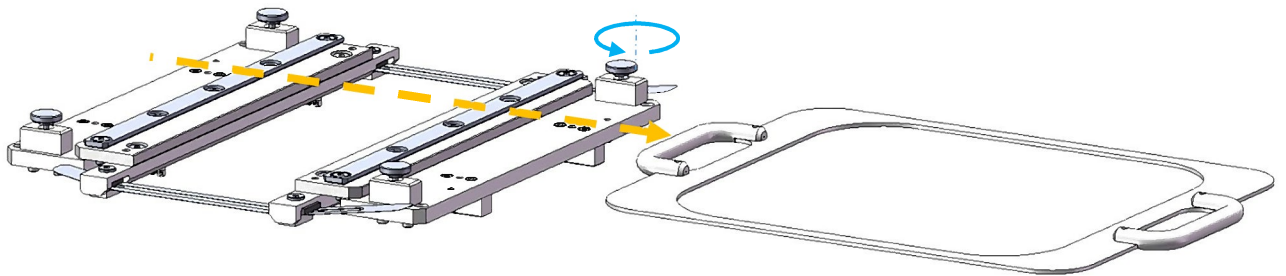

3. Tighten knurled-thumb-screws to prevent accident that the knurled-thumb-screw drop off from the jig during operation.

CAUTION Tightening torque: 3.0 N·m (do not over tighten screws)

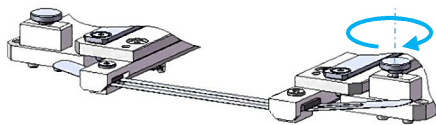

3.3 Safety Cover

WARNING Install a safety cover and prevent access to any moving parts.

CAUTION Fix the safety cover surely to prevent accidents by of the vibration.

INTERLOCK Cannot operate equipment with the operation panel whenever the safety cover opened.

3.3.1 ATTACH THE COVER on THE TESTING JIG [Tool: ---]

1) Loosen four screws-with-knurled-resin-head.

NOTE Do not remove screws.

2) Attach the cover on the test jig.

NOTE Confirm direction of the safety cover as below.

CAUTION Do not strike the cover against the micro switch.

CAUTION Confirm screws are fit in the ditch of the cover.

3) Fix the safety cover with four screws.

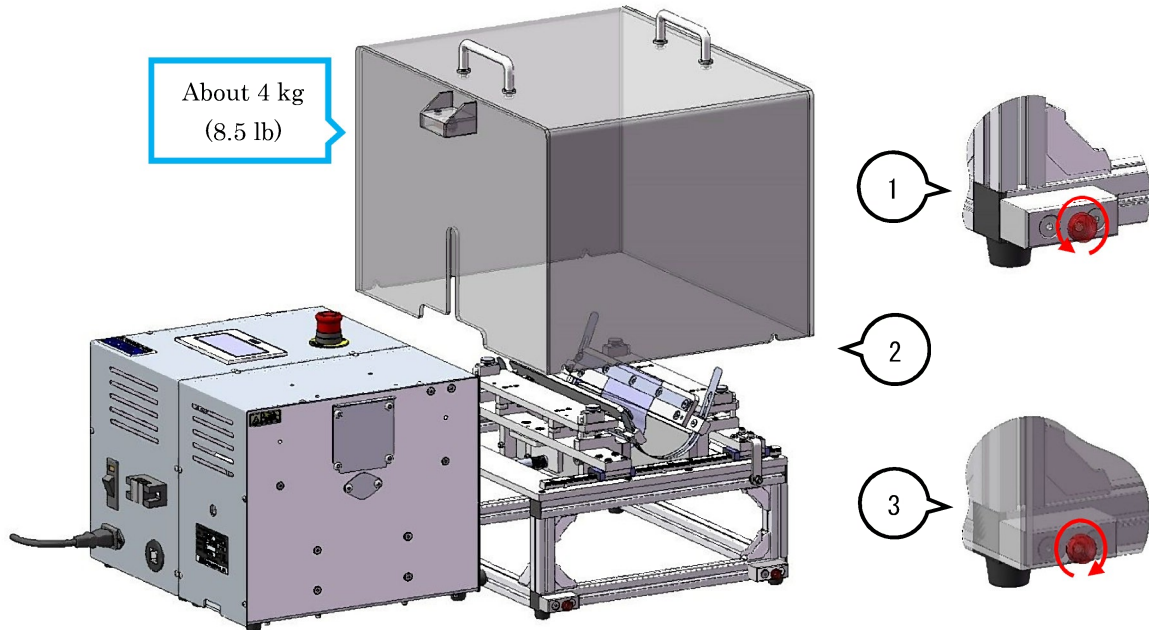

4. MAINTENANCE and INSPECTION

4.1 INSPECTION

This Jig is maintenance-free.

Change to the new one if some components will go bad or break because of using condition or requirement.

Representative components

No	NAME	TYPE	Num.	MANUFACTURE (MATERIAL)	NOTE
1	Basic Unit, tension-free folding	ET254A002-010	1	YUASA SYSTEM	
2	Cartridge	ET254A007-001	1	YUASA SYSTEM	
3	Handling Plate	ET200P214-005	1	YUASA SYSTEM	
4	Knurled thumb screw	RNCB4-5-10	4	MISUMI	
5	Tension Spring	AUA4-30	2	YUASA SYSTEM	
6	Slip-Joint Hinge	YS061A001-001	4	YUASA SYSTEM	
7	Plate, Clamp	ET200P005-045	2	YUASA SYSTEM	
8	Clamp Pad	ET200P006-006	2	YUASA SYSTEM	
9	Tilt Controller	ET200P165-006	2	YUASA SYSTEM	
10	Support, Tilt Controller	ET200P170-002	4	YUASA SYSTEM	
11	Support, Tilt Controller	ET200P170-006	4	YUASA SYSTEM	
12	Extra low head cap screw	CBSM5-12	8	MISUMI	
13	C-rube Linear Way	MLG12C2R300HS1	2	IKO	
14	Cover, Test Jig	ET500A003-027	1	YUASA SYSTEM	
15	Screw with Knurled Resin Head	CRKR4-12	4	MISUMI	

4.1.1 CHANGE TILT CONTROLLERS [Tool: 3 mm Allen Wrench]

- Change the tilt controller to new one when the tilt controller is broken.

NOTICE Change two tilt controllers (1 set) even so only one of the tilt controller will break.

- 1) Locate the moving slider to the rearmost position to make workspace.

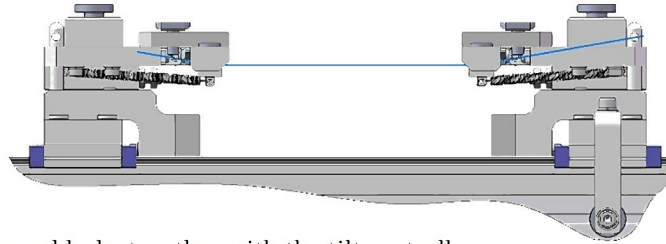

- 2) Loosen screws and remove clamp blocks together with the tilt controller.

NOTE Because there is a small part, be careful not to be lost.

- 3) Assemble the tilt controller with clamp blocks.

CAUTION Make sure the posture of clamp blocks.

NOTE Tilt Controller: ET200P165-006

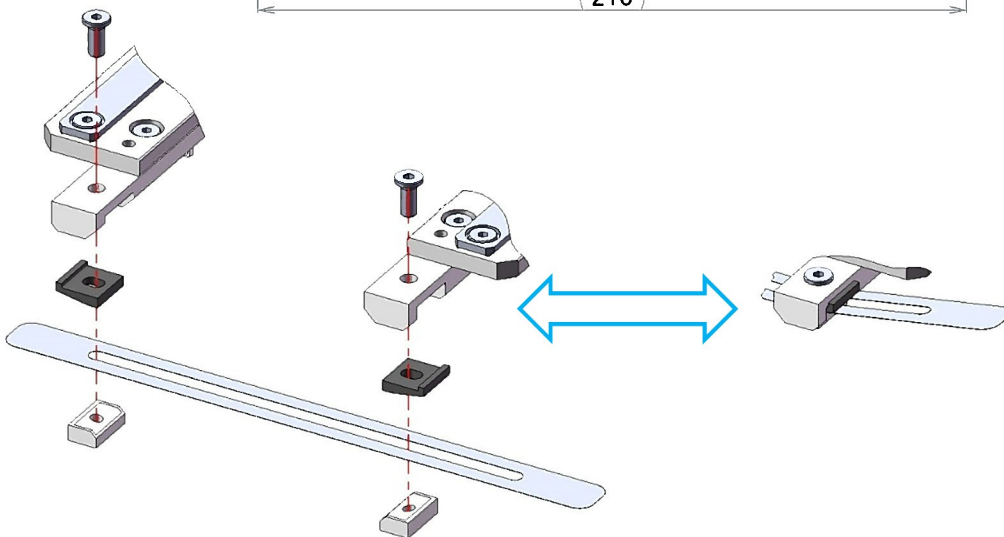
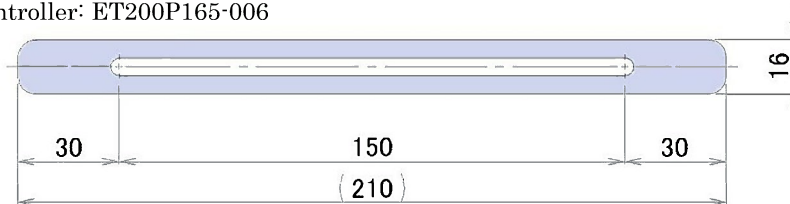

- 4) Tighten screws which on the moving slider to fix tilt controllers.

CAUTION Tightening torque: 3.0 N·m (do not over tighten screws)

- 5) Remove screws which fixed tilt clamps.

NOTE Tilt clamps will tilts freely.

- 6) Adjust tilt controllers to test condition.

Case of broken





YouTube help to understand how to set up the test jig.
Please cover the communication fee.

Quick Reference with Website

Add a keyword into the address bar from our website to access the quick reference.



<http://www.yuasa-system.jp/en>



<http://www.yuasa-system.jp/manuals/ET254M002-010>

YUASA

YUASA SYSTEM CO., LTD.

~ Further Improve Reliability

<http://www.yuasa-system.jp> ~

KIBITSU FACTORY:	2292-1, Kibitsu, Kita-ku, Okayama-shi, OKAYAMA 701-1341, JAPAN	Tel. +81-86-287-9030 / Fax. +81-86-287-2298
TOKYO OFFICE:	3F, Shinbashi SN BLDG, 5-7-10, Shinmachi, Minato-ku, TOKYO 105-004, JAPAN	Tel. +81-3-3578-8515 / Fax. +81-3-3578-8516
OSAKA OFFICE:	8F, NLC Shin-Osaka Earth-BLDG, 5-1-3, Miyahara, Yokogawa-ku, Osaka-shi, OSAKA 532-003, JAPAN	Tel. +81-6-6394-8175 / Fax. +81-6-6397-2632

The Contents of the instruction manual may change to improve without notice.